

Accurate Regulation of your Flow

SPC-2 Sanitary Electro-Pneumatic Modulating Valve

Application

SPC-2 is a sanitary electro-pneumatic modulating valve for use in stainless steel pipe systems.

Typical applications of SPC-2 are control of pressure, flow, temperature, level in tanks etc.

Working principle

SPC-2 is remote-controlled by an electrical signal and compressed air. The valve is available with a normally open (NO) actuator as standard but can be supplied with a normally closed (NC) actuator. The actuator can easily be changed from a NO-version to a NC-version or vice versa.

The IP-converter, which is an integrated part of the actuator, converts the electrical signal to a pneumatic signal. This signal conversion is extremely insensitive to pressure shocks.

The pneumatic signal is transmitted to the integrated positioner which operates by means of the force-balance principle, ensuring that the position of the actuator piston is directly proportional to the input signal. Signal range and zero point can be adjusted individually.

The actuator can be used for split-range operation by using a different measuring spring.

Standard design

The valve consists of valve body, valve plug, lip seal, bonnet and an external actuator. The actuator with the bonnet is fitted to the valve body by means of a clamp.

The actuator has an integrated IP-converter and positioner which offers substantial advantages compared to externally fitted positioners. All the moving parts are enclosed in the actuator and therefore well protected against damage and dirt.

The actuator has few moving parts, and two main actuator sizes cover all valve sizes.



SPC-2, normally open (NO).

Capacity diagram

For $\Delta p = 100 \text{ kPa (1bar)}$.

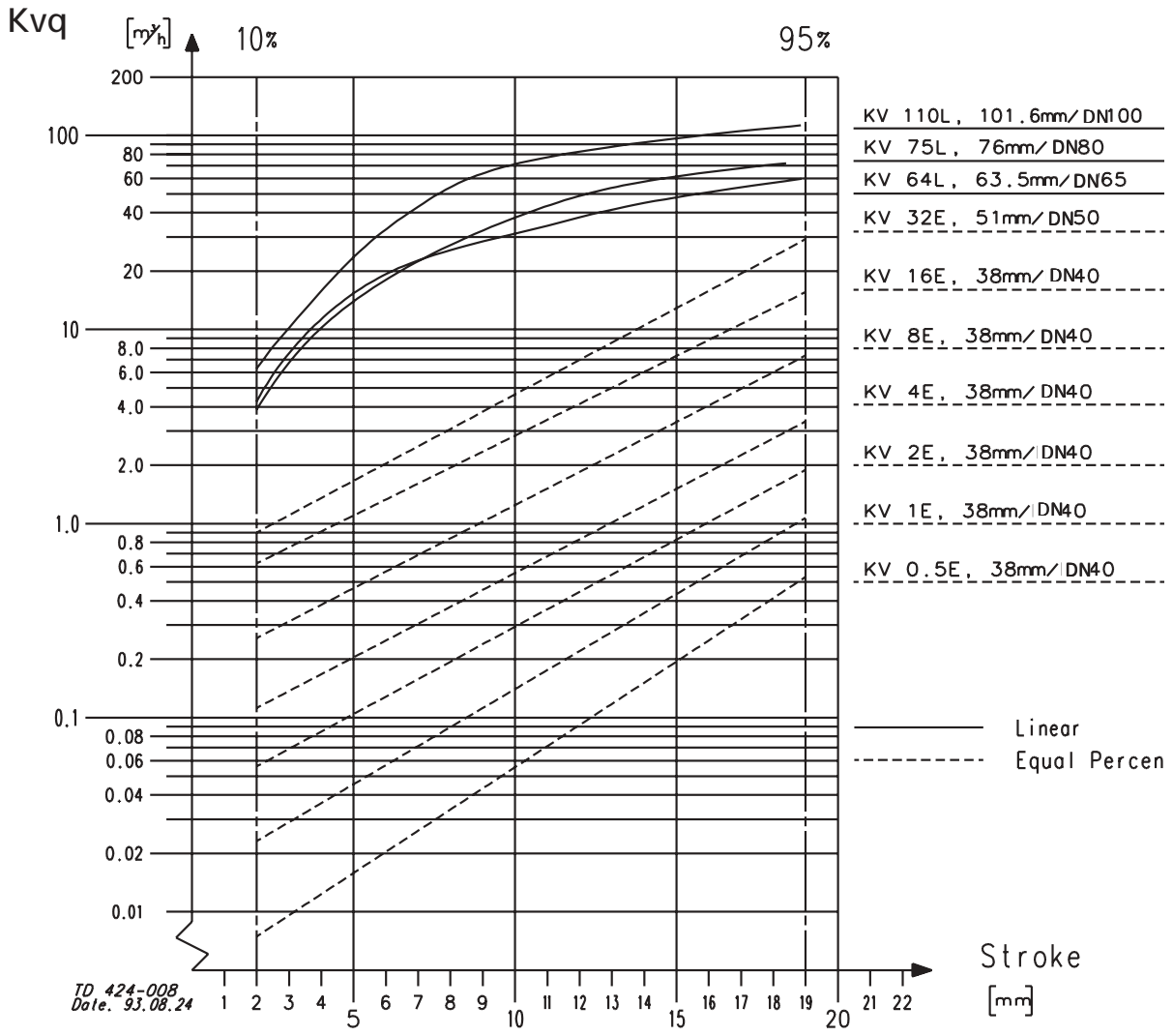

TD 424-008
Date: 93.08.24

NOTE! For the diagram the following applies:
Medium: Water (20°C).
Measurement: In accordance with VDI 2173.

Pressure drop calculation

The Kv designation is the flow rate in m^3/h at a pressure drop of 1 bar when the valve is fully open (water at 20°C or similar liquids).

To select the Kv value it is necessary to calculate the Kv_q value using the following formula:

$$Kv_q = \frac{Q}{\sqrt{\Delta p}}$$

Where:

Kv_q = Kv value at specific flow and specific pressure drop.

Q = Flow rate (m^3/h).

Δp = Pressure drop over valve (bar).

Technical data**Valve:**

Max. product pressure:	1000 kPa (10 bar).
Min. product pressure:	Full vacuum.
Temperature range:	-10°C to 140°C (EPDM).
Flow range Kv (Dp = 1bar):	0.5 to 110 m ³ /h.
Max. pressure drop:	500 kPa (5 bar).

Actuator:**Air quality**

Air connection:	6/4 air tube with air fitting R1/8" (BSP)
Max. pressure:	600 kPa (6 bar).
Working pressure:	400 kPa (4 bar).
Max. size of particles:	0.01 mm.
Max. oil content:	0.08 ppm.
Dew point:	10°C below ambient temp. or lower.
Max. water content:	7.5 g/kg.

I/P converter

Signal range:	4 - 20 mA (standard).
Input resistance:	200 Ω.
Inductivity/capacitance:	Negligible.

Accuracy

Deviation:	≤1.5%.
Hysteresis:	≤0.5%.
Sensitivity:	<0.1%.
Influence of air supply pressure:	≤0.1% between 1.4 and 6 bar.

Air consumption at steady state condition: With 0.6 bar signal pressure and supply pressures up to 6 bar ≤100 l/h.

Protection class: IP 54.

Ambient temperature: -25°C to +70°C.

Materials**Valve:**

Product wetted steel parts:	Acid-resistant steel, 1.4404 (316L).
Other steel parts:	Stainless steel, 1.4301(304).
Product wetted seals:	EPDM rubber.
Finish:	Semi-bright.

Actuator:

Actuator cases:	Aluminium with plastic coating.
Diaphragms:	NBR with reinforced fabric insert.
Springs:	Stainless steel uncovered/spring steel epoxy resin coated.
Actuator stem:	Stainless steel.
Plastic parts:	Polyamide.
Screws, nuts:	Stainless steel, polyamide.
Other parts:	Stainless steel.

Dimensions (mm)

Size	38	51	63.5	76.1	101.6		40	50	65	80	100	
	mm	mm	mm	mm	NO	NC	DN	DN	DN	DN	NO	NC
A	414	419	444	455	491	509	414	419	444	455	491	509
E	55	62	67	84	96	96	55	62	67	84	96	96
G	49.5	62	82	87	134	134	49.5	62	82	87	134	134
H	168	168	168	168	168	280	168	168	168	168	168	280
OD	37.9	50.8	63.5	76.1	101.6	101.6	41	53	70	85	104	104
ID	34.9	47.6	60.3	72.1	97.6	97.6	38	50	66	81	100	100
t	1.5	1.6	1.6	2.0	2.0	2.0	1.5	1.5	2.0	2.0	2.0	2.0
M/ISO clamp	21	21	21	21	21	21						
M/ISO male	21	21	21	21	21	21						
M/DIN male							22	23	25	25	30	30
M/SMS male	20	20	24	24	35	35						
M/BS male	22	22	22	22	27	27						
Weight (kg)	7.5	8.2	14.0	15.0	18.3	27.3	7.5	8.2	14.0	15.0	18.3	27.3

Flow sizes/tube connections

Kv	Seat diam. (mm)	Tube connections (mm)		Actuator (type no.)	
		ISO	DIN/DN	NO	NC
0,5 E	6	38	40	3277-5	3277-5
1,0 E	10	38	40	3277-5	3277-5
2 E	12	38	40	3277-5	3277-5
4 E	14	38	40	3277-5	3277-5
8 E	23	38	40	3277-5	3277-5
16 E	29	38	40	3277-5	3277-5
32 E	48.5	51	50	3277-5	3277-5
64 L	51	63.5	65	3277-5	3277-5
75 L	51	76.1	80	3277-5	3277-5
110 L	72	101.6	100	3277-5	3277

Options

- A) Male parts or clamp liners in accordance with required standard.
- B) Aseptic version based on ARC diaphragm system.
- C) 3A approved version (polished).
- D) Explosion protection (EEX ia IIc T6) on request.
- E) 3A (Sanitary Standard) labelling on request.
- F) Lip seal of Nitrile (NBR) or Fluorinated rubber (FPM).

Ordering

- Please state the following when ordering:
- Valve size (Kv or flow and pressure drop).
 - Actuator version, NO or NC.
 - Connections if not welding ends.
 - Other options.

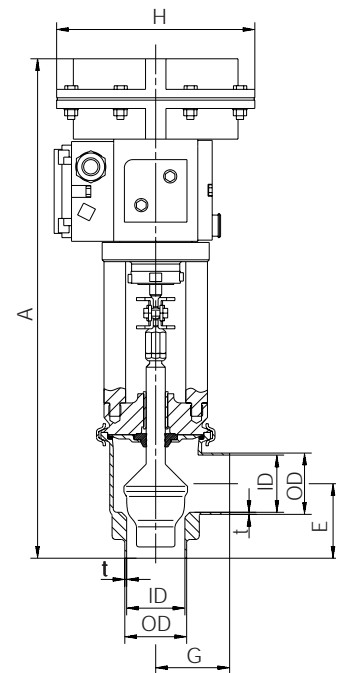

a. SPC-2, normally open (NO).

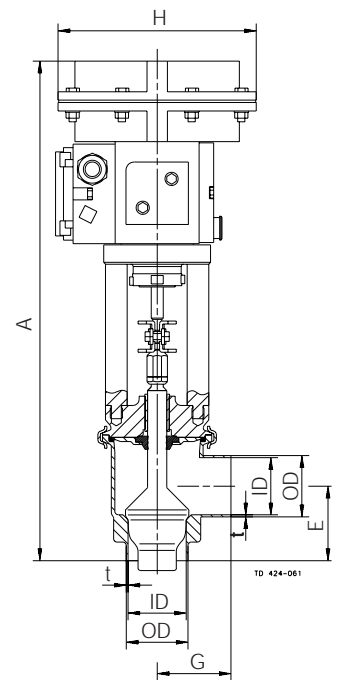

b. SPC-2, normally closed (NC).

Dimensions.

Note! For further details, see also PD 65036 and instruction IM 70736.