

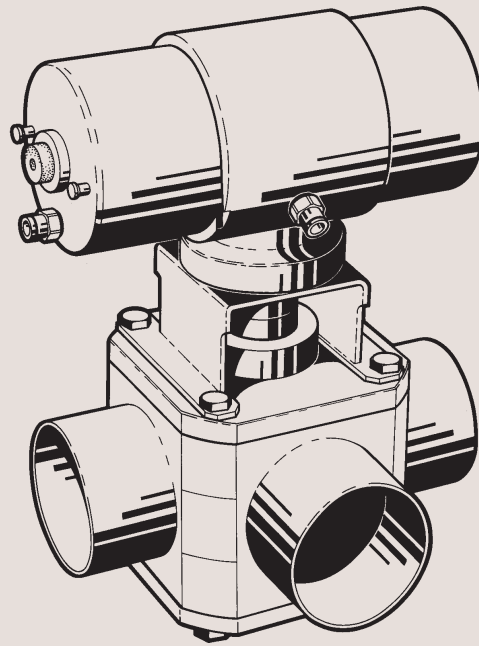

Operating Manual

MH Koltek Valve



IM70735-GB4 1998-05

Declaration of Conformity

The designating company

Alfa Laval

Company Name

6000 Kolding

Address

+45 79 32 22 00

Phone No.

hereby declare that

Koltek Valve

Denomination

MH

Type

Year

Was manufactured in conformity with the provisions in the COUNCIL DIRECTIVE of 14 June 1989 on mutual approximation of the laws of the Member States on the safety of machines (89/392/EEC as amended by directives 91/368/EEC and 93/44/EEC) with special reference to Annex 1 of the directive on essential safety and health requirements in relation to the construction and manufacture of machines.

Bjarne Søndergaard

Name

Vice President, R & D

Title

Alfa Laval

Company



Signature

Designation



Table of contents

This manual is divided into main sections. - See below.

Safety	1. Important information 2
	2. Warning signs 2
	3. Safety precautions 3
Installation	1. Unpacking/Delivery 4
	2. General installation 5
	3. Welding 6
Operation	1. Operation 7
	2. Fault finding 8
	3. Recommended cleaning 9
Maintenance	1. General maintenance 10
	2. Dismantling of valve 12
	3. Reassembly of valve 13
	4. Dismantling of actuator
	- type 631/632 15
	- type 630 16
	- type 633 17
	5. Reassembly of actuator
	- type 631/632 18
	- type 630 19
	- type 633 20
	6. Dismantling/reassembly of special indication units 21
	7. Shutter adjustment 22
Technical data	1. Technical data 23
Drawings/Parts list	1. Parts lists
	- Valve 24+26
	- Actuator type 631/632 28+30
	- Actuator type 630 32+34
	- Actuator type 633 36+38
	2. Exploded drawings
	- Valve 25
	- Actuator type 631/632 29
	- Actuator type 630 33
	- Actuator type 633 37
	3. Drawings
	- Valve 27
	- Actuator type 631/632 31
	- Actuator type 630 35
	- Actuator type 633 39
Appendix	Spare parts

Safety

Unsafe practices and other important information are emphasized in this manual.

Warnings are emphasized by means of special signs.

1. Important information

Always read the manual before using the valve!

WARNING!

: Indicates that special procedures **must** be followed to avoid severe personal injury.

CAUTION!

: Indicates that special procedures **must** be followed to avoid damage to the valve.

NOTE!

: Indicates important information to simplify practices or to make them clearer.

2. Warning signs



: General warning.



: Caustic agents.

All warnings in the manual are summarized on this page.

Pay special attention to the instructions below so that severe personal injury and/or damage to the valve are avoided.

3. Safety precautions

Installation:



- : - **Always** read the technical data thoroughly (see page 23).
- **Always** release compressed air after use.



- : **Never** touch the valve or the pipelines when processing hot liquids or when sterilizing.



- : **Never** dismantle the valve with valve and pipelines under pressure.

Operation:



- : - **Always** read the technical data thoroughly (see page 23).
- **Always** release compressed air after use.



- : **Never** touch the valve or the pipelines when processing hot liquids or when sterilizing.



- : **Always** handle lye and acid with great care.

Maintenance:



- : - **Always** read the technical data thoroughly (see page 23).
- **Always** release compressed air after use.



- : - **Never** service the valve when it is hot.
- **Never** service the valve with valve and pipelines under pressure.



- : **Never** stick your fingers through the valve ports if the actuator is supplied with compressed air.

Installation

4

Study the instructions carefully and pay special attention to the warnings!

The valve has ends for welding as standard but can also be supplied with fittings.

1. Unpacking/Delivery

1

CAUTION!

The valve is delivered with shutter loosened. Always adjust shutter before installing and operating the valve (see special instructions on page 22)!

- **Always** read the technical data thoroughly (see page 23).
- **Always** release compressed air after use.

CAUTION!

We cannot be held responsible for incorrect unpacking.

2

Check the delivery for:

1. Complete valve.
2. Delivery note.
3. Instruction Manual.

3

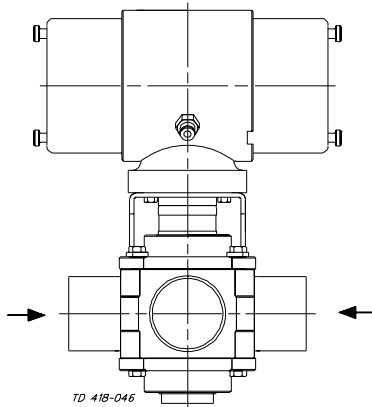

Remove possible packing materials from valve/ valve ports.

4

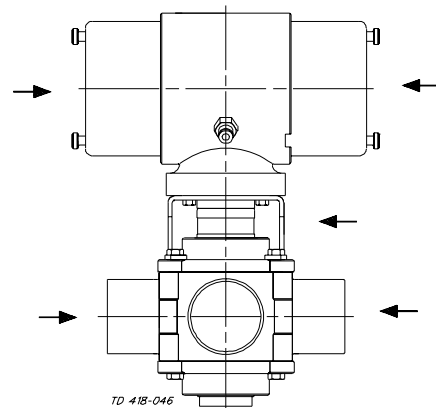

Inspect the valve for visible transport damages.

5

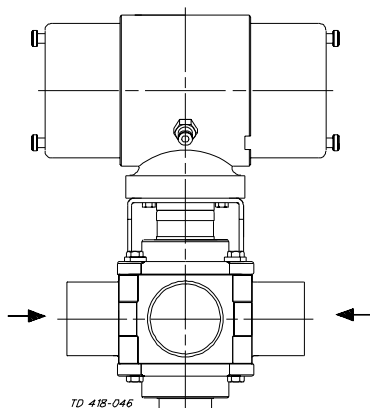

Avoid damaging the valve/valve ports.

Study the instructions carefully and pay special attention to the warnings!

The valve has ends for welding as standard but can also be supplied with fittings.
A/A = Air/air activated.

2. General installation

1



- **Always** read the technical data thoroughly (see page 23).
- **Always** release compressed air after use.

CAUTION!

We cannot be held responsible for incorrect installation.

2

Risk of damage!

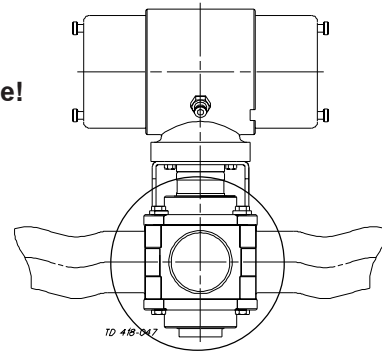

Avoid stressing the valve

Pay special attention to:

- Vibrations.
- Thermal expansion of the tubes.
- Excessive welding.
- Overloading of the pipelines.

3

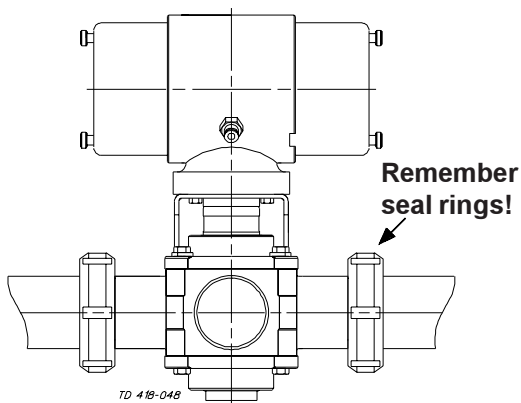

Fittings:

Ensure that the connections are tight.

4

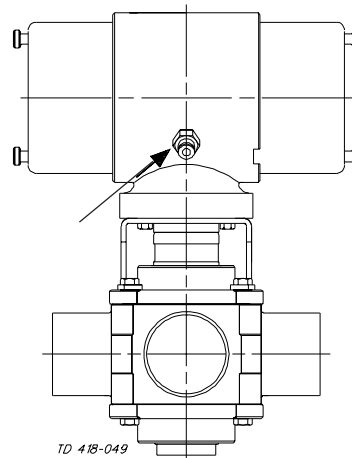

Air connection:

R 1/8" (BSP), 6/4 mm hose.

Installation

Study the instructions carefully and pay special attention to the warnings!
The valve has welding ends as standard.

Weld carefully.
Adjust shutter before operating the valve.
Check the valve for smooth operation after welding.

3. Welding

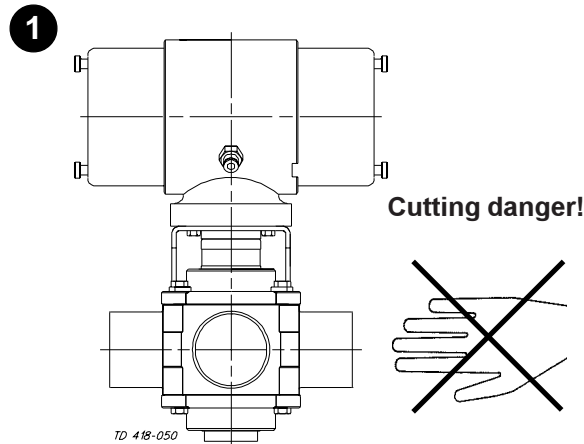

! Never stick your fingers through the valve ports if the actuator is supplied with compressed air.

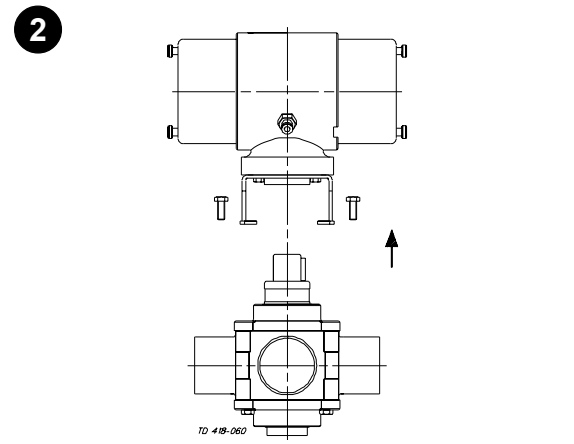

Dismantle the valve in accordance with instructions on page 12.
Pay special attention to the warnings!

3

Maintain the minimum clearances (A, B and C) so that the actuator and internal valve parts can be removed.

Valve size	A	B	C
25 mm/DN25	144	142	214
38 mm/DN40	193	186	263
51 mm/DN50	209	202	279
63.5 mm/DN65	234	230	304
76.1 mm/DN65 welded	264	265	334
DN80	325	343	395
101.6 mm/DN100	355	373	425

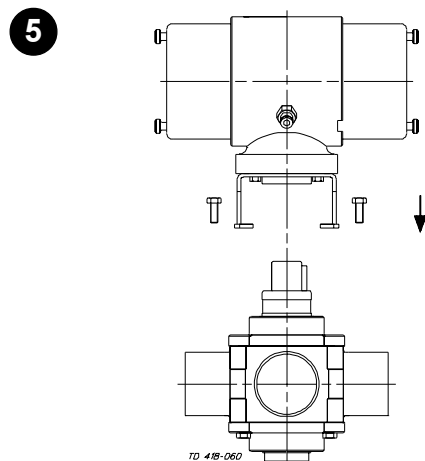
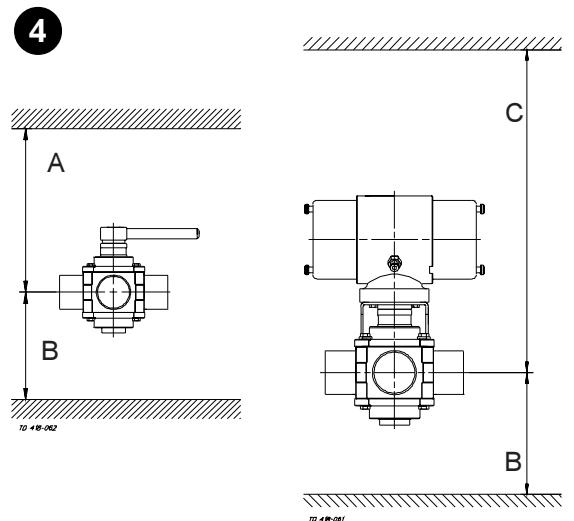

Reassemble the valve in accordance with instructions on page 13 after welding.
Pay special attention to the warnings!

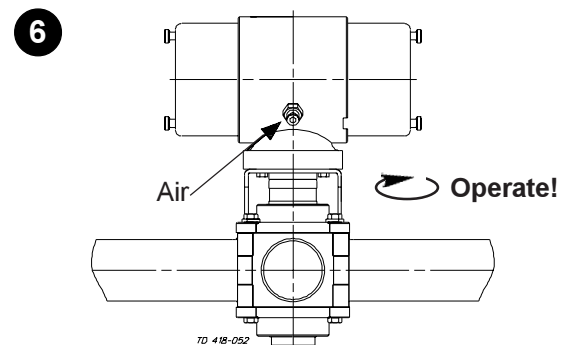

CAUTION!
Adjust shutter before operating the valve!

Pre-use check:

1. Supply compressed air to the air fitting(s).
2. Operate the valve to ensure that it runs smoothly (see checkpoints on page 14).

Pay special attention to the warnings!

Study the instructions carefully and pay special attention to the warnings!

Ensure that the valve operates smoothly.

1. Operation

1



- **Always** read the technical data thoroughly (see page 23).
- **Always** release compressed air after use.

CAUTION!

We cannot be held responsible for incorrect operation.

2

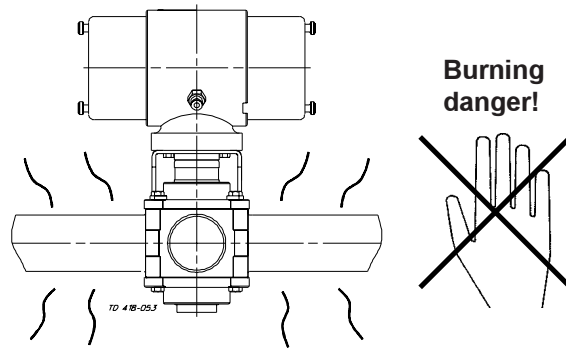

Never touch the valve or the pipelines when processing hot liquids or when sterilizing.

3

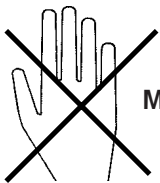

Moving part!

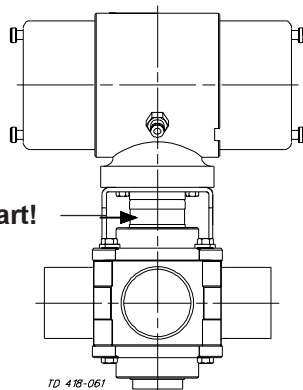

4

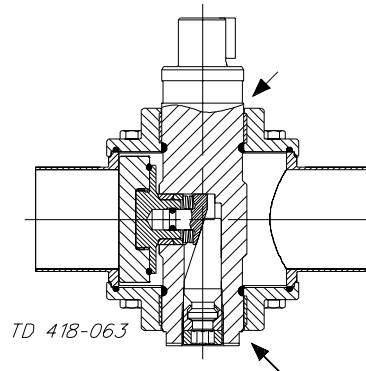

Lubrication of valve:

1. Ensure smooth movement of the valve (the valve is lubricated before delivery).
2. Lubricate with silicone oil/grease if necessary.



Never touch the spindle if the actuator is supplied with compressed air.

5

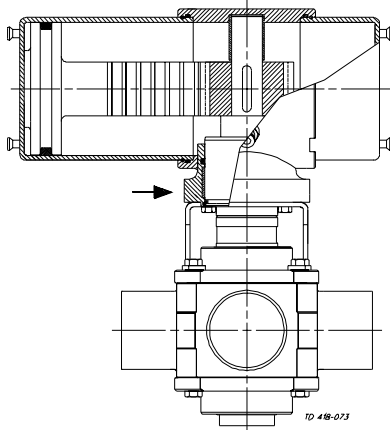

Lubrication of actuator:

1. Ensure smooth movement of the actuator (the actuator is lubricated before delivery).
2. Lubricate with silicone oil/grease if necessary.

Pay attention to possible faults.

Study the instructions carefully.
The items refer to the drawings and parts list on pages 24-27.

2. Fault finding

NOTE!

Study the maintenance instructions carefully before replacing worn parts. - See page 10!

8

Problem	Cause/result	Repair
The shutter jerks	<ul style="list-style-type: none"> - The shutter needs adjustment - Worn shutter - Compressed cup springs 	<ul style="list-style-type: none"> - Adjust the shutter (see page 22) - Replace the shutter - Replace cup springs
Product leakage at valve body/lids	<ul style="list-style-type: none"> - Worn/product affected O-rings (3) - Loose screws (1) 	<ul style="list-style-type: none"> - Replace the O-rings - Tighten screws
Product leakage at lids/shaft	Worn/product affected O-rings (4)	Replace the O-rings
Product leakage shutter/tightened device	The shutter needs adjustment	Adjust the shutter NB! Clean inner parts
Product leakage (too high pressure against shutter)	<ul style="list-style-type: none"> - Too high pressure - the shutter needs adjustment - Worn shutter 	<ul style="list-style-type: none"> - Adjust the shutter - change flow direction (see page 22) - Replace the shutter
The valve does not open/close	<ul style="list-style-type: none"> - Faulty wedge (10) - The pressure on the shutter is too high - Worn actuator O-rings - Worn bearing - Shutter adjusted too hard 	<ul style="list-style-type: none"> - Replace the wedge - Reduce the pressure - Replace O-rings - Replace bearing - Adjust shutter

Study the instructions carefully and pay special attention to the warnings!

NaOH = Caustic Soda.
HNO₃ = Nitric acid.

3. Recommended cleaning

1 Caustic danger!



Always use rubber gloves!



Always use protective goggles!



Always handle lye and acid with great care.

3

Examples of cleaning agents:

Use clean water, free from chlorides.

1. 1% by weight NaOH at 70° C.

1 kg NaOH	+	100 l water	= Cleaning agent.
--------------	---	----------------	-------------------

2.2 l 33% NaOH	+	100 l water	= Cleaning agent.
-------------------	---	----------------	-------------------

2. 0.5% by weight HNO₃ at 70° C.

0.7 l 53% HNO ₃	+	100 l water	= Cleaning agent.
-------------------------------	---	----------------	-------------------

5

Always rinse!

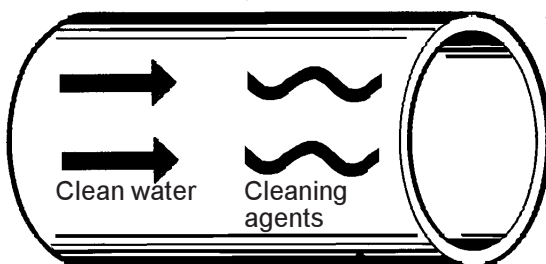

Always rinse well with clean water after the cleaning.

2

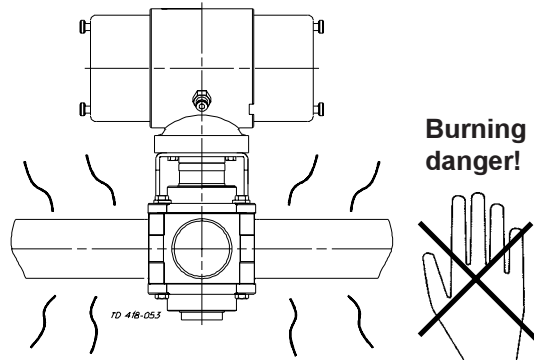

Never touch the valve or the pipelines when sterilizing.

4

1. Avoid excessive concentration of the cleaning agent

⇒ Dose gradually!

2. Adjust the cleaning flow to the process

⇒ Milk sterilization/viscous liquids

⇒ Increase the cleaning flow!

3. Flip the valve during cleaning, if possible.

NOTE!

The cleaning agents must be stored/disposed of in accordance with current rules/directives.

Maintenance

10

Maintain the valve regularly.
Study the instructions carefully and pay special attention to the warnings!

Always keep spare seals in stock.

1. General maintenance

1



- Always read the technical data thoroughly (see page 23).
- Always release compressed air after use.

NOTE!

All scrap must be stored/disposed of in accordance with current rules/directives.

2

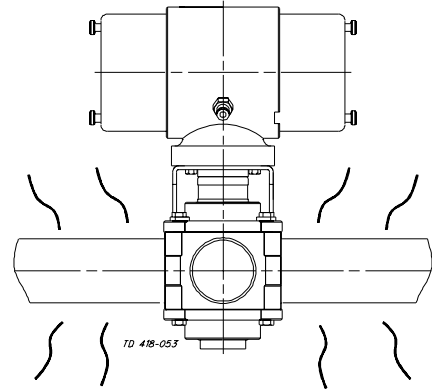

- Never service the valve when it is hot.
- Never service the valve with valve and pipelines under pressure.

3

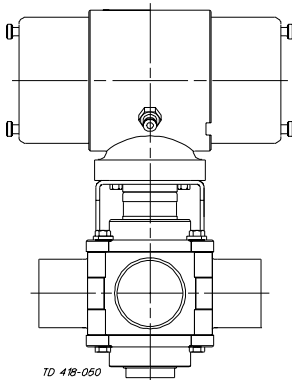

Cutting danger!

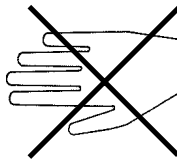

Never stick your fingers through the valve ports if the actuator is supplied with compressed air.

4



Moving part!

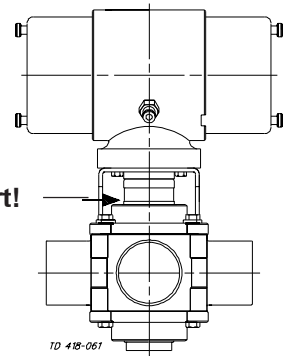

Never touch the spindle if the actuator is supplied with compressed air.

Ordering spare parts

- Contact the Sales Department.
- Order from the Spare Parts List.

Recommended spare parts: Service kits (see Spare Parts List).

Maintain the valve regularly.
Study the instructions carefully.

Always keep spare rubber seals in stock.
Check the valve for smooth operation after service.

1. General maintenance

	Valve rubber seals	Shutter	Actuator rubber seals
Preventive maintenance	Replace after 12 months	Adjust shutter after every 1500 turns	Replace after 5 years
Maintenance after leakage (leakage normally starts slowly)	Replace at the end of the day	Adjust shutter	Replace when possible
Planned maintenance	<ul style="list-style-type: none"> - Regular inspection for leakage and smooth operation - Keep a record of the valve - Use the statistics for planning of inspections 	Regular inspection for wear and smooth operation	<ul style="list-style-type: none"> - Regular inspection for leakage and smooth operation - Keep a record of the actuator - Use the statistics for planning of inspections
Lubrication	Before fitting: Silicone oil or silicone grease (USDA H1 approved oil/grease)		Before fitting: Oil or grease

Pre-use check:

1. Supply compressed air to the actuator.
 2. Operate the valve several times to ensure that it runs smoothly.
- Pay special attention to the warnings!**

Maintenance

12

Study the instructions carefully.
The items refer to the drawings and parts list on pages 24-27.

Handle scrap correctly.
A/A = Air/air activated.

2. Dismantling of valve

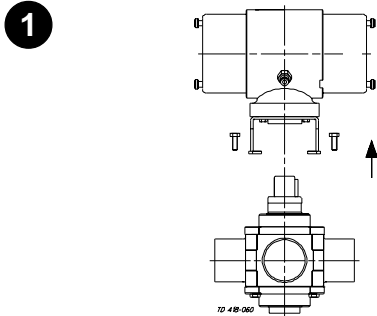

⚠ Never dismantle the valve with valve and pipelines under pressure.

Air-operated valve:

1. Loosen and remove screws (1).
2. Lift out the actuator and bonnet from the valve.
3. Remove top lid (2) from valve body (7).

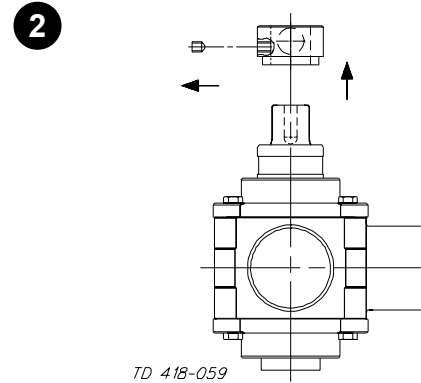

Manually operated valve:

1. Loosen the screw in handle (11).
2. Remove the handle from shaft (5).
3. Loosen and remove screws (1) and top lid (2) from valve body (7).

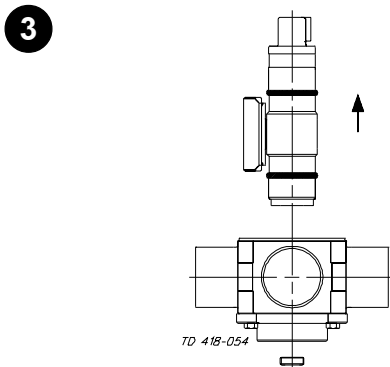

1. Loosen safety screw (9) and tightening device (8).
2. Pull out shaft (5) with shutter unit (6) from the valve body.
3. Loosen and remove screws (1) and bottom lid (2) from the valve body (if needed).

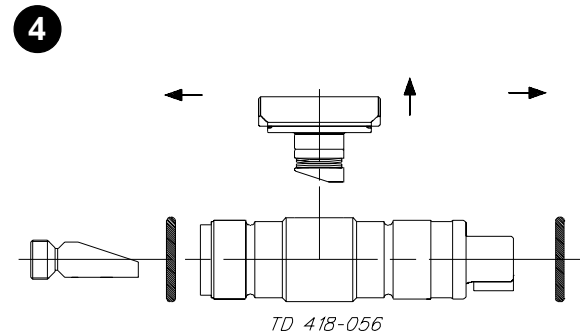

1. Pull out shutter unit (6) from shaft (5).
2. Remove tightening device (8) from shaft (5) (if necessary).
3. Pull off O-rings (4) from shaft (5).

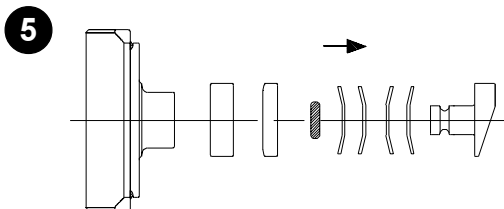

1. Pull out adjustment key (6d) from the shutter.
2. Remove support ring (6c) and seal ring (6b) from shutter (6a).
3. Pull off O-ring (6f) and cup springs (6e) from the adjustment key.

NOTE!

When replacing the shutter replace the entire shutter unit.

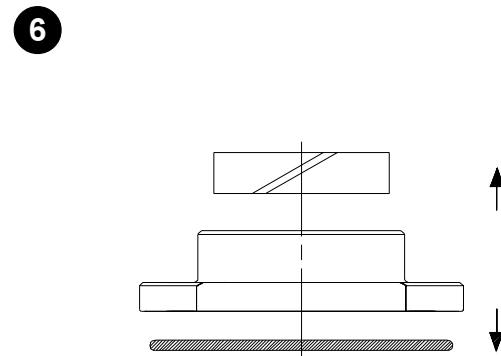

Pull out O-rings (3) and guide rings (2a) from lids (2).

Study the instructions carefully.
The items refer to the drawings and parts list on pages 24-27.
A/A = Air/air activated.

3. Reassembly of valve

1

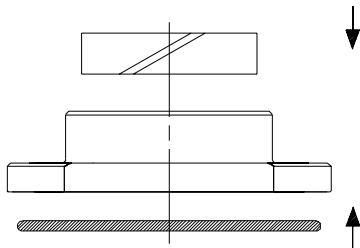

TD 418-058

Fit O-rings (3) and guide rings (2a) in lids (2).

3

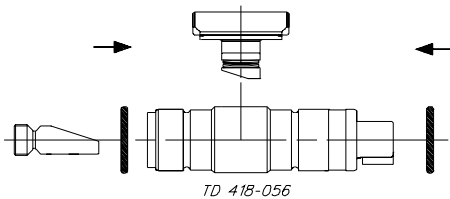

TD 418-056

1. Slide O-rings (4) onto shaft (5).
2. Push shutter unit (6) into shaft (5).
3. Ensure that the sloping surfaces of tightening device (8) and adjustment key (6d) get in contact (lubricate).
4. Screw tightening device (8) lightly into shaft (5) (lubricate).

5

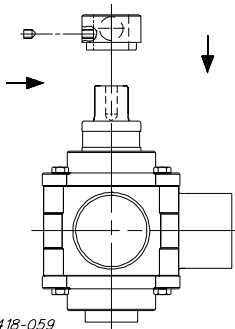

TD 418-059

Manually operated valve:

1. Fit top lid (2) on the valve body and tighten screws (1).
2. Adjust the tightness of the shutter according to the procedure on page 22.
3. Fasten safety screw (9) after shutter adjustment.
4. Fit handle (11) on shaft (5) with wedge (10) and tighten the screw.

2

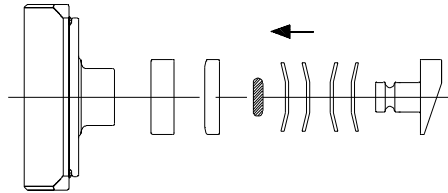

TD 418-055

1. Ensure that seal ring (6b) and support ring (6c) are fitted on shutter (6a).
2. Slide cup springs (6e) onto adjustment key (6d) - RE-MARK position!
3. Slide O-ring (6f) onto the adjustment key .
4. Push the adjustment key into shutter (6a).

4

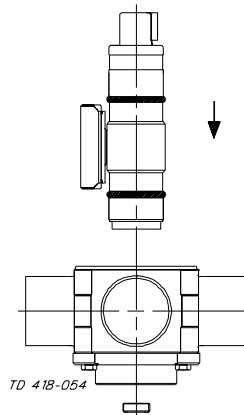

TD 418-054

1. Fit bottom lid (2) on valve body (7) and tighten screws (1) (if dismantled).
2. Slide shaft (5) with shutter unit (6) into the valve body.

6

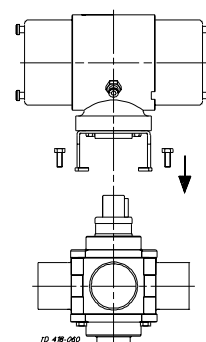

TD 418-060

Air-operated valve:

1. Fit top lid (2) and the bonnet on the valve body and tighten screws (1).
2. Adjust the tightness of the shutter according to the procedure on page 22.
3. Fasten safety screw (9) after shutter adjustment.

Maintenance

14

Study the instructions carefully.
The items refer to the drawings and parts list on pages 24-27.

Lubricate all O-rings with silicone oil or similar before reassembly.

3. Reassembly of valve (checkpoints)

7

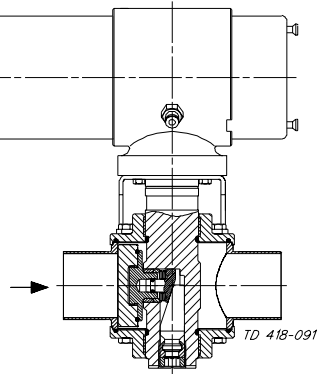

Air-operated valve:
Check that the shutter unit exactly covers the correct outlet.

8

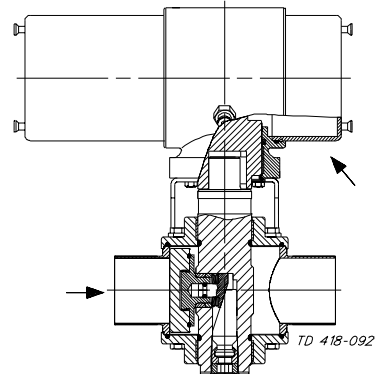

Air-operated valve:
Check that the position of the actuator fits the position of the shutter unit.

9

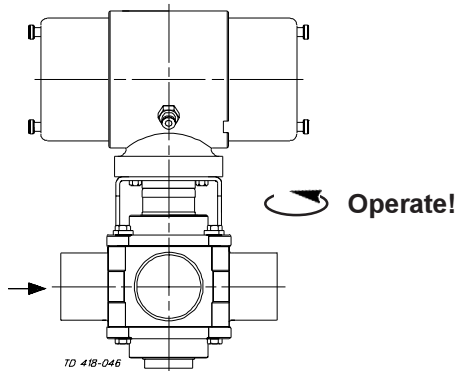

1. Check that the shutter opens/closes correctly.
2. Check the valve for smooth operation after reassembly.

Pay special attention to the warnings!

Study the instructions carefully.
The items refer to the drawings and parts list on pages 28-39.

Handle scrap correctly.

4. Dismantling of actuator, type 631/632

1

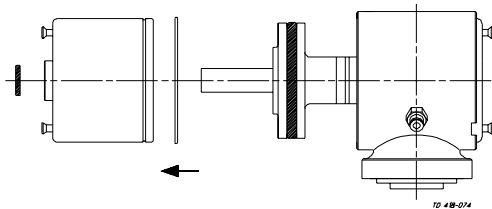

1. Turn cylinder (16 or 16a) anticlockwise to unhook lock wire (19) and remove the lock wire (turn the cylinder slightly clockwise to loosen the lock wire).
2. Remove the cylinder from chassis (1).
3. Pull out O-ring (15) from cylinder (16a) (only with indication) (only remove cylinder (17) if damaged).

2

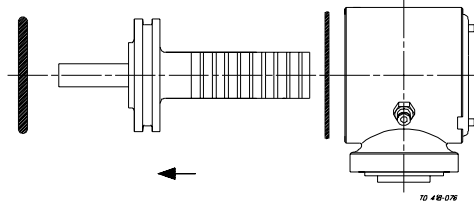

1. Pull out piston (10) from chassis (1). (For sizes 89-101.6 mm/DN80-100: both pistons).
2. Pull off O-ring (11) from the piston. (For sizes 89-101.6 mm/DN80-100: both O-rings from both pistons).

3

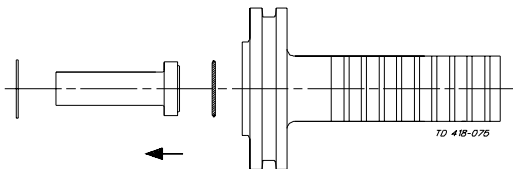

4

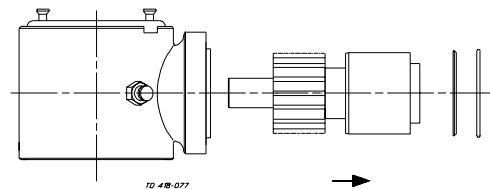

Only cylinders with indication:

1. Remove circlip (14) from piston (10).
2. Take out indication stem (12) from the piston.
3. Pull off O-ring (13) from the indication stem.

1. Remove lock ring (9) and bearing (8) from chassis (1).
2. Pull out spindle (2) from the chassis/piston.

5

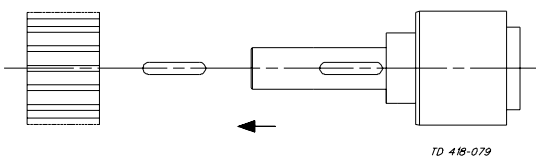

6

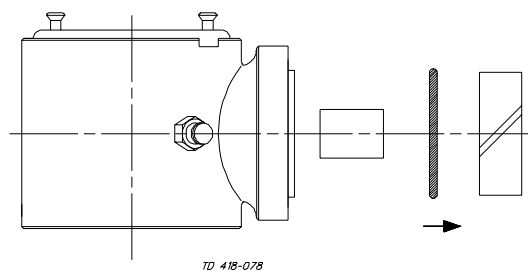

Remove gear wheel (4) and wedge (3) from spindle (2).

Pull out guide ring (7), O-ring (6) and bearing (5) from chassis (1). Tap the bearing loose with a rubber hammer, if necessary.

Maintenance

16

Study the instructions carefully.
The items refer to the drawings and parts list on pages 28-39.
The auxiliary equipment is not supplied by Alfa Laval.

Lubricate all O-rings with silicone oil or similar before reassembly.

4. Dismantling of actuator, type 630

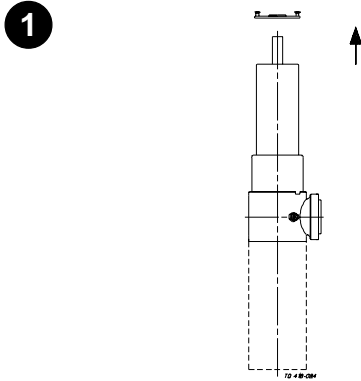

For sizes 63.5-76.1 mm/DN65 with indication:

1. Loosen and remove screws (26a) and cylinder lid (26).
2. Place chassis/cylinders (1/ 16, 17) in the auxiliary equipment.

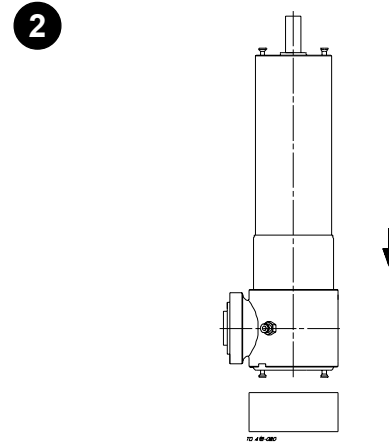

Position the auxiliary equipment with chassis/cylinder in a press.

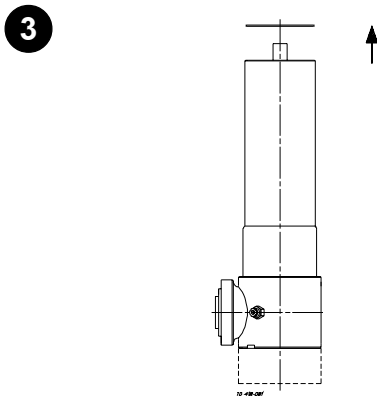

1. Press flange (24) into cylinder (16) using the press (with indication: flange (24) is replaced by flange(25)).
2. Remove lock wire (23) from the cylinder.
3. Remove the flange.

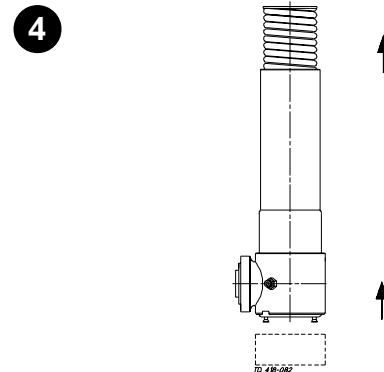

1. Remove chassis/cylinder (1/ 16, 17) from the auxiliary equipment.
2. Take out spring (22) from the cylinder.

NOTE!

For sizes 63.5-76.1 mm/DN65, instructions 1-4 on this page are repeated.

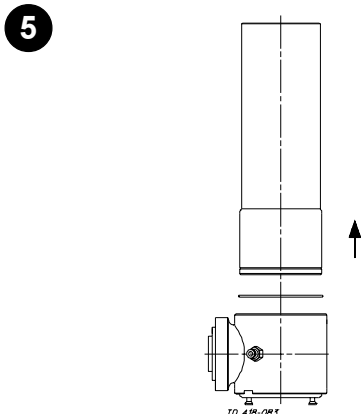

1. Turn cylinder (16) anticlockwise to unhook lock wire (19). Use a strapping tool to turn the cylinder.
2. Remove the cylinder from chassis (1).

6

Continue the dismantling by following instructions 2-6 on page 15.

Study the instructions carefully.
The items refer to the drawings and parts list on pages 28-39.

Handle scrap correctly.

4. Dismantling of actuator, type 633

1

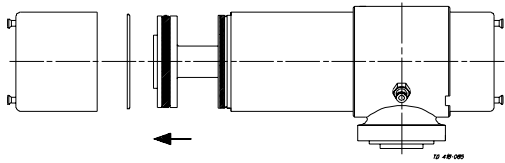

1. Turn auxiliary cylinder (28) anticlockwise to unhook lock wire (31).
2. Remove the auxiliary cylinder from cylinder (16).

2

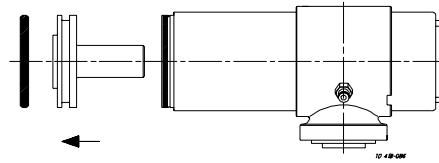

1. Pull out auxiliary piston (29) from cylinder (16).
2. Pull off O-ring (11) from the auxiliary piston.

3

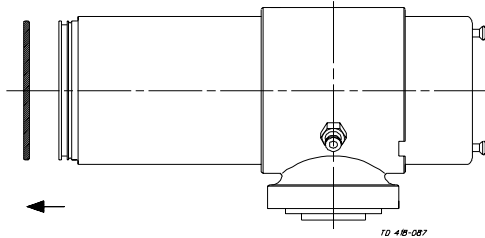

Pull off O-ring (30) from cylinder (16).

NOTE!

For sizes 89-101.6 mm/DN80-100, instructions 1-3 on this page are repeated.

4

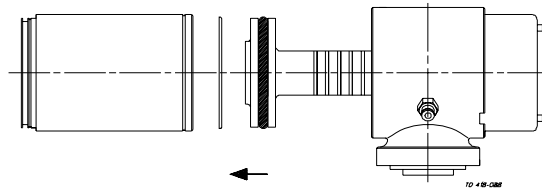

1. Turn cylinder (16) anticlockwise to unhook lock wire (19). Use a strapping tool to turn the cylinder.
2. Remove the cylinder from chassis (1).
3. Repeat this procedure for cylinder (17), if necessary.

5

Continue the dismantling by following instructions 2-6 on page 15.

Maintenance

18

Study the instructions carefully.
The items refer to the drawings and parts list on pages 28-39.

Lubricate all O-rings with silicone oil or similar before reassembly.

5. Reassembly of actuator, type 631/632

1

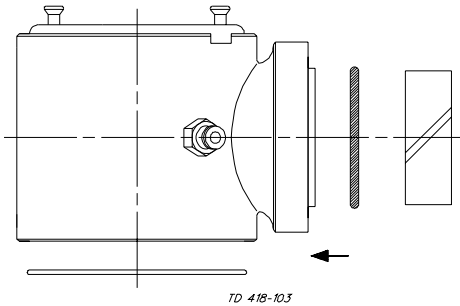

Fit guide ring (7) and O-rings (6,18) in chassis (1).

2

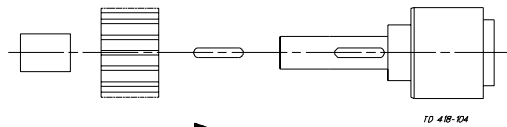

1. Fit wedge (3), gear wheel (4) and bearing (5) on spindle (2) (lubricate).
2. Guide/work the spindle into the chassis.

3

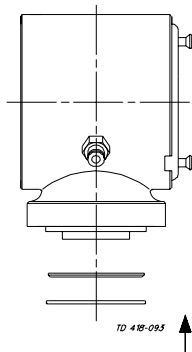

Fit bearing (8) and lock ring (9) into chassis (1).

WARNING!

Make sure that the lock ring is fitted well in its groove.

4

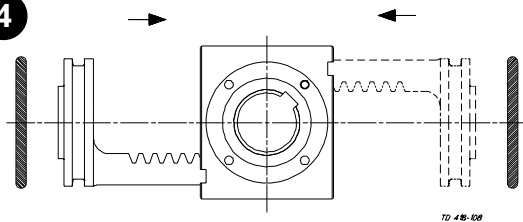

1. Adjust spindle (2) so that the notch has a 45° angle to piston(s) (10).
2. Position the piston(s) along the opposite inner sides of chassis (1) (lubricate teeth on piston(s) with grease type Longterm plus 2).
3. Press piston(s) into the chassis (at the same time for sizes 89-101.6 mm/DN80-100) (check that the notch has the correct angle to the piston(s)).
4. Slide O-ring(s) (11) onto the piston(s).

5

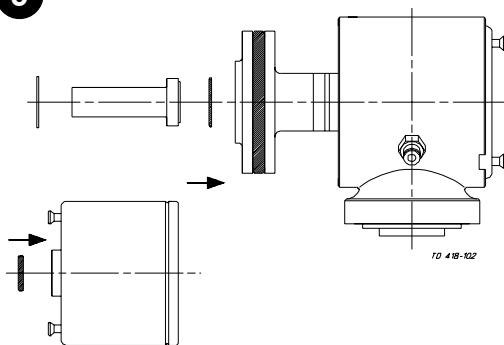

Only with indication:

1. Slide O-ring (13) onto indication stem (12).
2. Fit the indication stem in piston (10).
3. Fit circlip (14) in the piston.
4. Fit O-ring (15) in cylinder (16a).

6

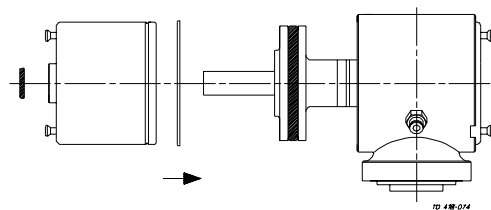

1. Fit cylinders (16/17) in the chassis (the notch in the chassis must be aligned with the dent in each cylinder).
2. Hook in lock wires (19) and turn each cylinder clockwise until the end of the lock wire slips into the notch in the chassis (turn cylinder slightly back to secure lock wire).

Study the instructions carefully.
The items refer to the drawings and parts list on pages 28-39.

Lubricate all O-rings with silicone oil or similar before reassembly.

5. Reassembly of actuator, type 630

1

Reassemble the actuator by following instructions 1-6 on page 18. Then proceed by following instructions 2-5 on this page.

2

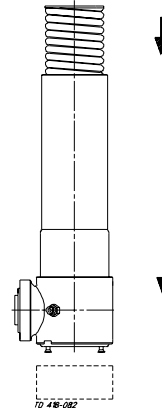

Place chassis/cylinder (1/ 17) in auxiliary equipment with mounted cylinder downwards. Fit spring (22) in the middle of cylinder (16) so that it does not contact the inner surface.

3

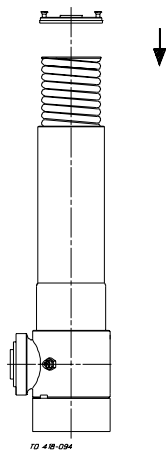

1. Place the auxiliary equipment with the cylinders in a press.
2. Fit flange (24) on the middle of spring (22).

4

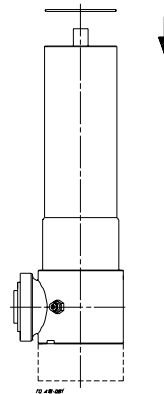

1. Press flange (24) into cylinder (16).
2. Fit lock wire (23) in the cylinder.
3. Remove the actuator from the press. (For sizes 63.5-76.1 mm/DN65, instructions 2-4 are repeated)

5

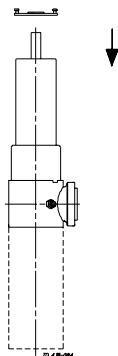

Only with indication:

Instructions 2-4 are repeated. When repeating these instructions use flange (25) instead of flange (24).

For sizes 63.5-76.1 mm/DN65: attach cylinder lid (26) to the cylinder with screws (26a).

Study the instructions carefully.
The items refer to the drawings and parts list on pages 28-39.

Lubricate all O-rings with silicone oil or similar before reassembly.

5. Reassembly of actuator, type 633

1

2

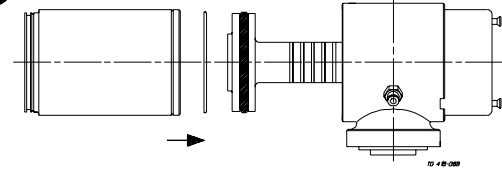

1. Fit cylinder (16) in chassis (1) (the notch in the chassis must be aligned with the dent in the cylinder).
2. Hook in lock wire (19) and turn the cylinder clockwise until the end of the lock wire slips into the notch in the chassis. Use a strapping tool (turn the cylinder slightly back to secure the lock wire).
3. Fasten cylinder (17) to the chassis the same way (if dismantled).

Reassemble the actuator by following instructions 1-3 on page 18. Then proceed by following instructions 2-5 on this page.

3

4

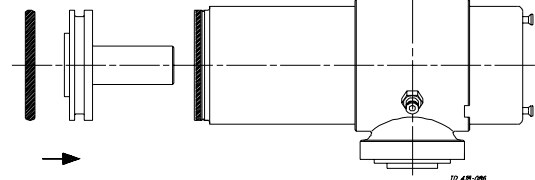
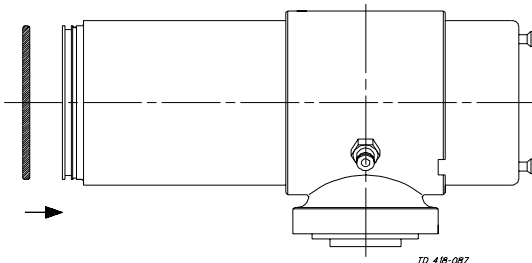

Fit O-ring (30) on cylinder (16).

1. Fit O-ring (11) on auxiliary piston (29).
2. Guide the auxiliary piston into cylinder (16).

5

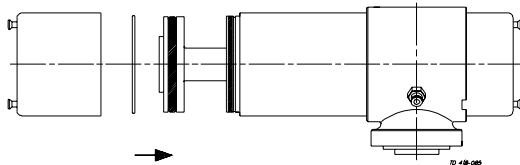

1. Fit auxiliary cylinder (28) on cylinder (16).
2. Hook in lock wire (23) and turn the auxiliary cylinder clockwise until the end of the lock wire slips into the hole in the cylinder.

NOTE!

For sizes 89-101.6 mm/DN80-100, instructions 3-5 on this page are repeated.

Study the instructions carefully.
The items refer to the drawings and parts list on pages 28-39.

Lubricate all O-rings with silicone oil or similar before reassembly.

6. Dismantling/Reassembly of special indication units

1

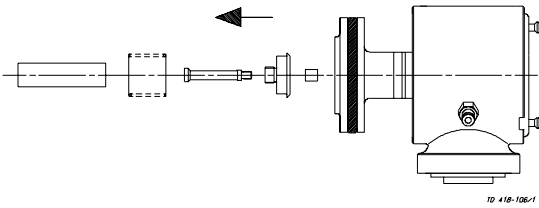

Dismantling - telescope indication:

1. Pull off spring (12b) from screw (12c).
2. Unscrew and remove indication stem (12a) from the screw.
3. Unscrew and remove extension stem (12d) with screw from piston (10).

2

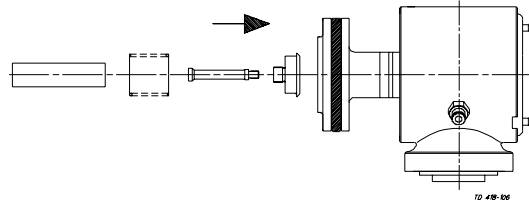

Reassembly - telescope indication:

1. Screw the extension stem with screw into piston (10). (Use Loctite 243).
2. Screw indication stem (12a) onto the screw.
3. Press/turn spring (12b) onto the screw.

3

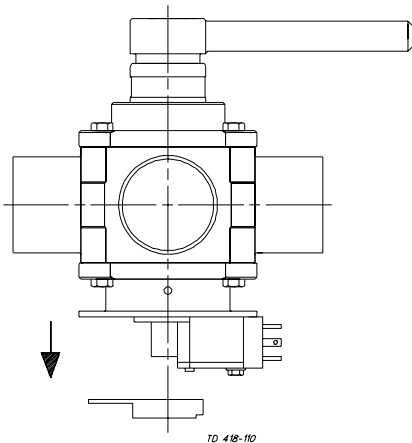

Dismantling - laterally fitted indication:

1. Loosen the screw in the indicator.
2. Pull off the indicator.

4

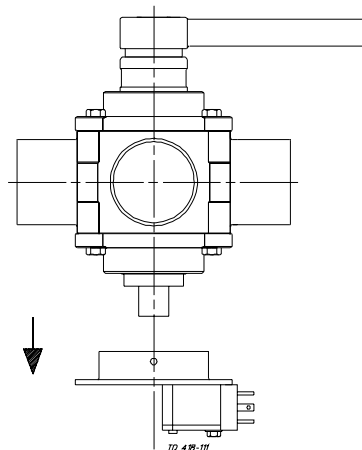

Dismantling - laterally fitted indication:

1. Loosen the screw(s) in the mounting bracket.
2. Remove the mounting bracket.

5

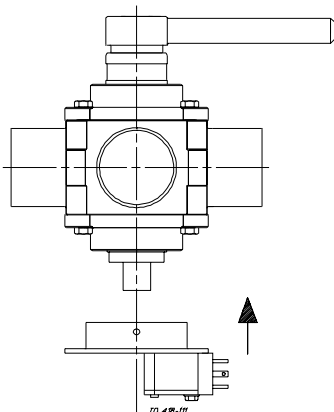

Reassembly - laterally fitted indication:

1. Fit the mounting bracket on the valve.
2. Tighten the screw(s) in the mounting bracket.

6

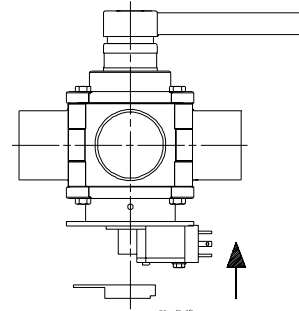

Reassembly - laterally fitted indication:

1. Fit the indicator.
2. Adjust the indicator/mounting bracket and tighten the screw.

NOTE!

Ensure that the indicator indicates all positions of the valve. For 180° actuator: Cut off the indicator pin to enable a full indicator turn.

Maintenance

Study the instructions carefully.
The items refer to the drawings and parts list on pages 24-27.

Adjust the shutter before operating the valve!

7. Shutter adjustment

1

NOTE!
All Koltek valves are delivered with shutter loosened after pressure test. The shutter must therefore be adjusted before operating the valve.
Adjust the shutter after every 1500 turns.

2

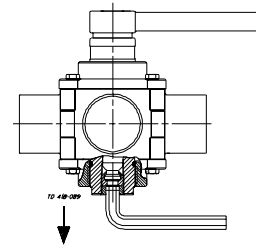

1. Put the shutter in neutral position (free of ports).
2. Loosen safety screw (9).
3. Holding an Allen key by the short length, tighten until resistance is felt.
4. Change the grip and, holding the Allen key by the long length, tighten the tightening device 1½ round (540°) further. Please note that the torque will only be an approximation using this method.

3

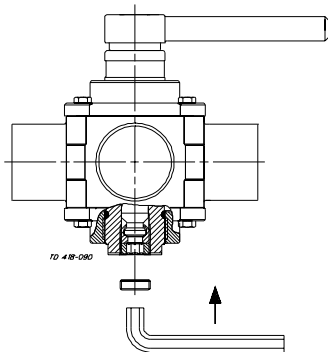

Fit safety screw (9) and tighten with the Allen key.

4

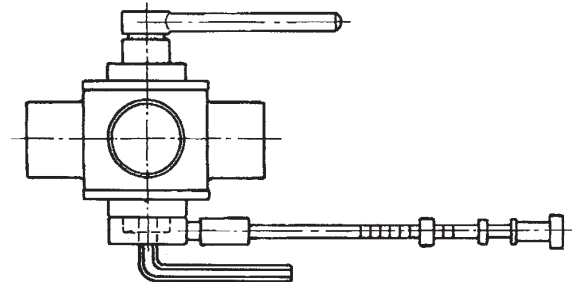

Alternative adjustment:

1. Bring shutter in neutral position.
2. Tightening device (8) is tightened with an Allen key until the required torque is achieved (see table below).

5

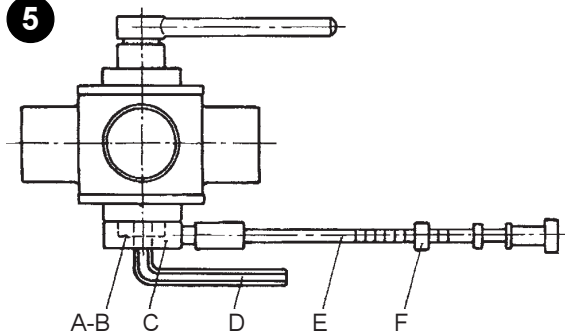

- A. Spindle.
- B. Adjusting screw.
- C. Driver.
- D. Allen key.
- E. Torque wrench.
- F. Adjusting scale.

6

NOTE!

If a torque wrench is used to determine the torque, the listed size of driver should be used on the lower end of shaft (5).

Recommended torque values, Nm:

Valvesize mm	Bearing			Size of driver
	Bronze	PTFE	Guide ring strip	
DN25/25mm	5	3	2	21
DN40/38mm	15	10	8	27
DN50/51mm	20	12	10	36
63mm	30	20	19	36
DN65/76.1mm	45	27	22	36
DN80	51	31	26	41
DN100/101.6mm	110	80	67	41

It is important to observe the technical data during installation, operation and maintenance.

Inform the personnel about the technical data.

1. Technical data

Data - valve

Max. pressure against shutter	300 kPa (3 bar)
Max. pressure behind shutter	1000 kPa (10 bar)
Temperature range	-10° C to +110° C

Data - actuator

Max. air pressure for actuator	800 kPa (8 bar)
Min. air pressure for actuator	500 kPa (5 bar)

Materials

Product wetted steel parts	AISI 316L
Finish	Semi bright
Other steel parts	AISI 304
Product wetted seals	EPDM
Other seals	Nitrile (NBR)
Shutter	PTFE

Drawing/Parts list

The drawings and the parts list include all items.

The items are identical with the items in the Spare Parts List.
When ordering spare parts, please use the Spare Parts List!

Parts list KOLTEK valve, type MH

24

Item	Quant.	Denomination
1	8	Screw
2	2	Lid
2a Δ	2	Guide ring (strip)
3 Δ	2	O-ring
4 Δ	2	O-ring
5	1	Shaft
6 Δ	1	Shutter unit
6a	1	Shutter
6b	1	Seal ring
6c	1	Support ring
6d	1	Adjustment key
6e	4	Cup spring
6f	1	O-ring
7	1	Valve body
8	1	Tightening device
9	1	Safety screw
10	1	Wedge
11	1	Handle
12	1	Screw

Δ : Recommended Spare Parts.

This page shows an exploded drawing of KOLTEK.

The drawing includes all items of the valve and the handle.
They are identical with the items in the Spare Parts List.

Exploded drawing

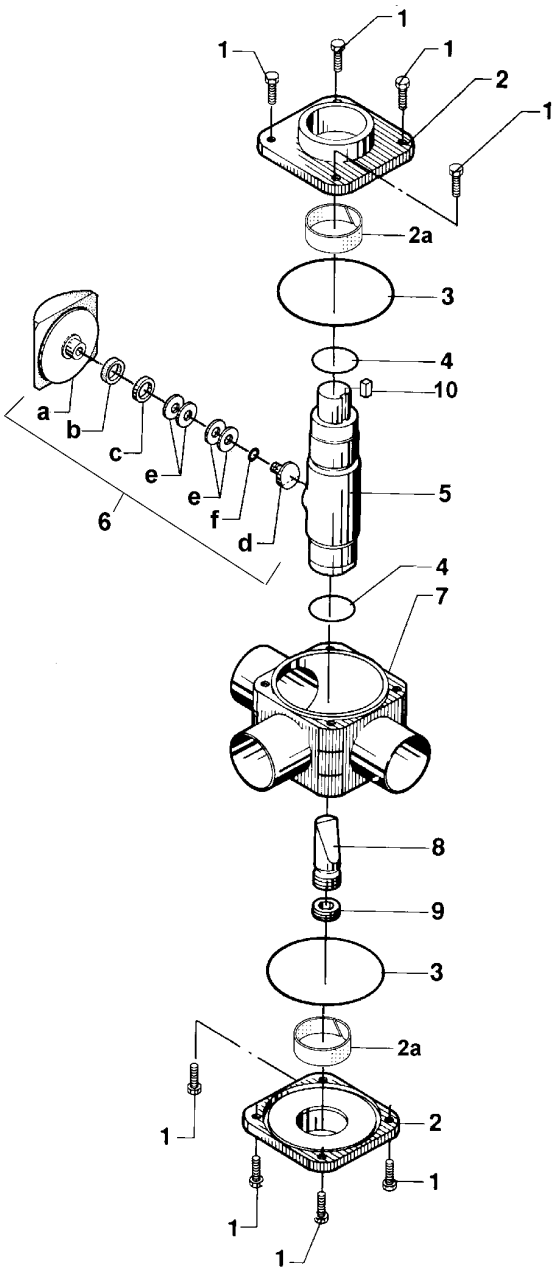

Bearing and lid for bearing

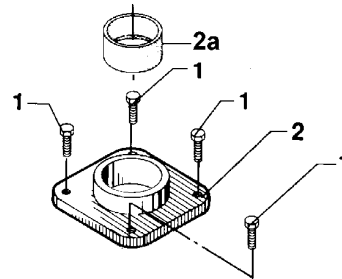

Handle

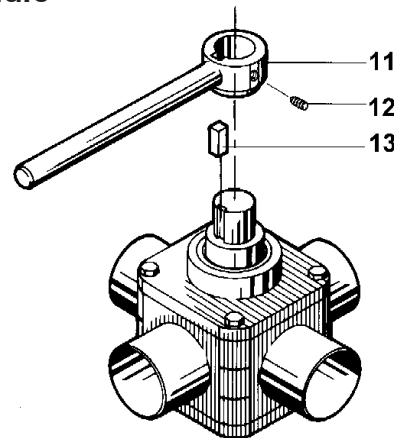

Drawing/Parts list

The drawings and the parts list include all items.

The items are identical with the items in the Spare Parts List.

When ordering spare parts, please use the Spare Parts List!

Parts list KOLTEK valve, type MH

26

Item	Quant.	Denomination
1	8	Screw
2	2	Lid
2a Δ	2	Guide ring (strip)
3 Δ	2	O-ring
4 Δ	2	O-ring
5	1	Shaft
6 Δ	1	Shutter unit
6a	1	Shutter
6b	1	Seal ring
6c	1	Support ring
6d	1	Adjustment key
6e	4	Cup spring
6f	1	O-ring
7	1	Valve body
8	1	Tightening device
9	1	Safety screw
10	1	Wedge
11	1	Handle
12	1	Screw

Δ : Recommended Spare Parts.

The drawings below show KOLTEK valve.

The items refer to the parts list on the opposite part of the page.

Drawings

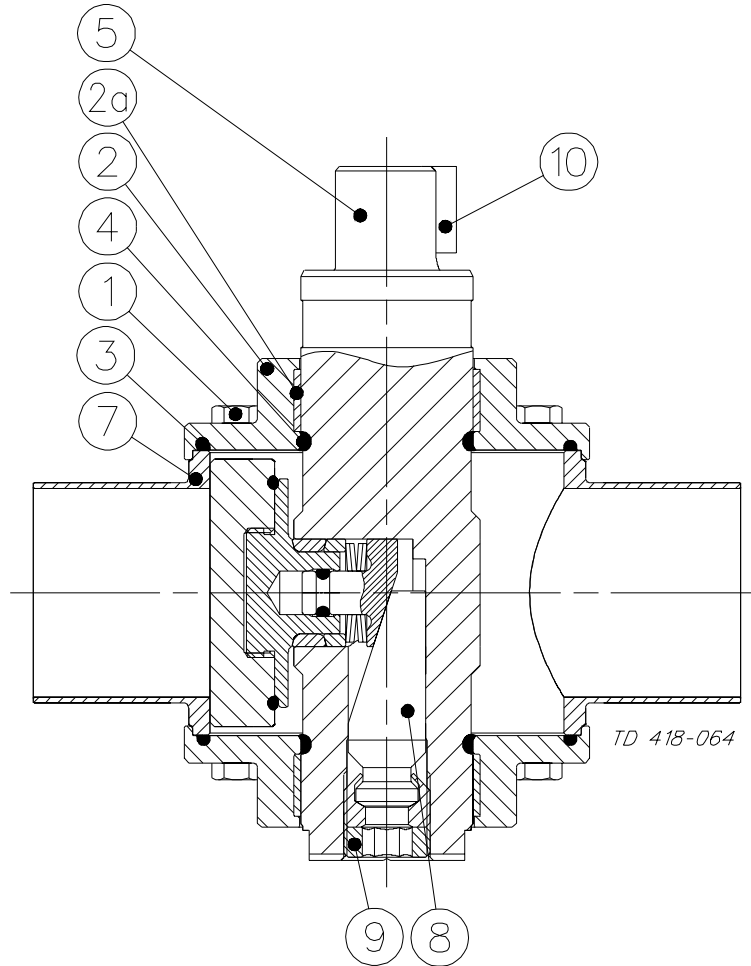

MH valve

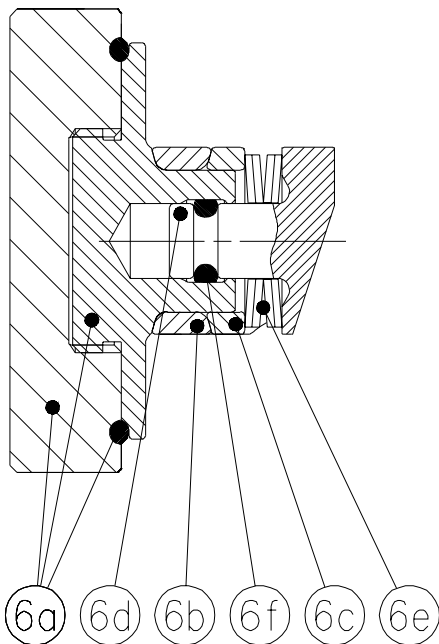

Shutter unit

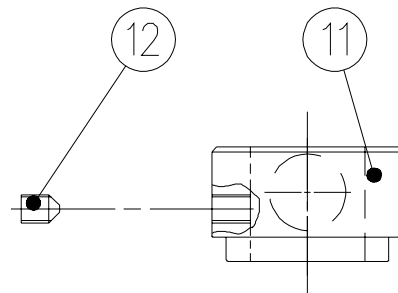

Handle

Drawing/Parts list

The drawings and the parts list include all items.

The items are identical with the items in the Spare Parts List.

When ordering spare parts, please use the Spare Parts List!

Parts list Actuator type 631/632

28

Item	Quant.	Denomination
1	1	Chassis
2	1	Spindle
3	1	Wedge
4	1	Gear wheel
5	1	Bearing
6 Δ	1	O-ring
7 Δ	1	Guide ring
8 Δ	1	Bearing
9	1	Lock ring
10	1	Piston
	2	Piston (type 631, sizes 80-101.6)
	2	Piston (type 632, sizes 80-101.6)
11 Δ	1	O-ring
	2	O-ring
	3	O-ring (type 633, sizes 25-76.1)
	4	O-ring (type 633, sizes 89-101.6)
12	1	Indication stem
a	1	Indication stem for telescope indication
b	1	Spring for telescope indication
c	1	Screw for telescope indication
d	1	Extension stem for telescope indication
13 Δ	1	O-ring
14	1	Circlip
15 Δ	1	O-ring
16	1	Cylinder
	2	Cylinder (type 630, sizes 63-76.1)
	2	Cylinder (type 633, sizes 89-101.6)
a	1	Cylinder for indication
17	1	Cylinder
18 Δ	2	O-ring
19	2	Lock wire
20	1	Bonnet
21	4	Screw
22	1	Spring (type 630, sizes 25-51)
	2	Spring (type 630, sizes 63-76)
23	1	Lock wire (type 630, sizes 25-51)
	2	Lock wire (type 630, sizes 63-76.1)
24	1	Flange
25	1	Flange for indication
26	1	Cylinder lid
a	2	Screw
27	1	Screw for indication stem
28	1	Auxiliary cylinder (type 633, sizes 25-76.1)
	2	Auxiliary cylinder (type 633, sizes 89-101.6)
29	1	Auxiliary piston (type 633, sizes 25-76.1)
	2	Auxiliary piston (type 633, sizes 89-101.6)
30 Δ	1	O-ring (type 633, sizes 25-76.1)
	2	O-ring (type 633, sizes 89-101.6)
31	1	Lock wire (type 633, sizes 25-76.1)
	2	Lock wire (type 633, sizes 89-101.6)
32	1	Air fitting (type 630)
	2	Air fitting (type 631, 632)
	3	Air fitting (type 633, sizes 25-76.1)
	5	Air fitting (type 633, sizes 89-101.6)
33	1	Guide for indication
34	1	Spindle extension (only for size 25)

Δ : Recommended Spare Parts.

This page shows an exploded drawing of KOLTEK.

The drawing includes all items of the actuator. They are identical with the items in the Spare Parts List.

Exploded drawing

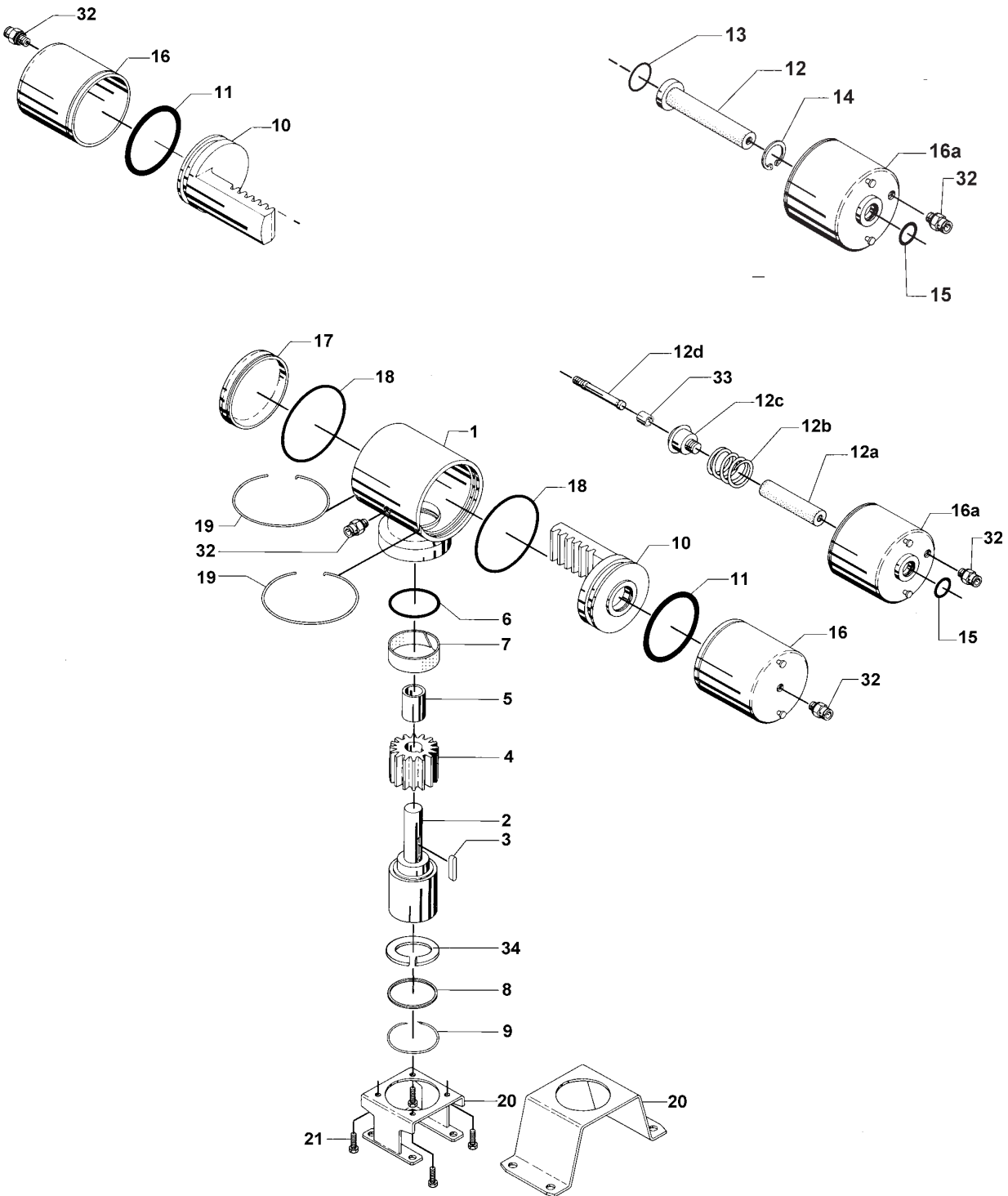

Drawing/Parts list

The drawings and the parts list include all items.

The items are identical with the items in the Spare Parts List.

When ordering spare parts, please use the Spare Parts List!

Parts list Actuator type 631/632

30

Item	Quant.	Denomination
1	1	Chassis
2	1	Spindle
3	1	Wedge
4	1	Gear wheel
5	1	Bearing
6 Δ	1	O-ring
7 Δ	1	Guide ring
8 Δ	1	Bearing
9	1	Lock ring
10	1	Piston
	2	Piston (type 631, sizes 80-101.6)
	2	Piston (type 632, sizes 80-101.6)
11 Δ	1	O-ring
	2	O-ring
	3	O-ring (type 633, sizes 25-76.1)
	4	O-ring (type 633, sizes 89-101.6)
12	1	Indication stem
a	1	Indication stem for telescope indication
b	1	Spring for telescope indication
c	1	Screw for telescope indication
d	1	Extension stem for telescope indication
13 Δ	1	O-ring
14	1	Circlip
15 Δ	1	O-ring
16	1	Cylinder
	2	Cylinder (type 630, sizes 63-76.1)
	2	Cylinder (type 633, sizes 89-101.6)
a	1	Cylinder for indication
17	1	Cylinder
18 Δ	2	O-ring
19	2	Lock wire
20	1	Bonnet
21	4	Screw
22	1	Spring (type 630, sizes 25-51)
	2	Spring (type 630, sizes 63-76)
23	1	Lock wire (type 630, sizes 25-51)
	2	Lock wire (type 630, sizes 63-76.1)
24	1	Flange
25	1	Flange for indication
26	1	Cylinder lid
a	2	Screw
27	1	Screw for indication stem
28	1	Auxiliary cylinder (type 633, sizes 25-76.1)
	2	Auxiliary cylinder (type 633, sizes 89-101.6)
29	1	Auxiliary piston (type 633, sizes 25-76.1)
	2	Auxiliary piston (type 633, sizes 89-101.6)
30 Δ	1	O-ring (type 633, sizes 25-76.1)
	2	O-ring (type 633, sizes 89-101.6)
31	1	Lock wire (type 633, sizes 25-76.1)
	2	Lock wire (type 633, sizes 89-101.6)
32	1	Air fitting (type 630)
	2	Air fitting (type 631, 632)
	3	Air fitting (type 633, sizes 25-76.1)
	5	Air fitting (type 633, sizes 89-101.6)
33	1	Guide for indication
34	1	Spindle extension (only for size 25)

Δ : Recommended Spare Parts.

The drawings below show KOLTEK actuators.

The items refer to the parts list on the opposite part of the page.

Drawings

Type 631 (sizes 25-76.1 mm/DN25-65)

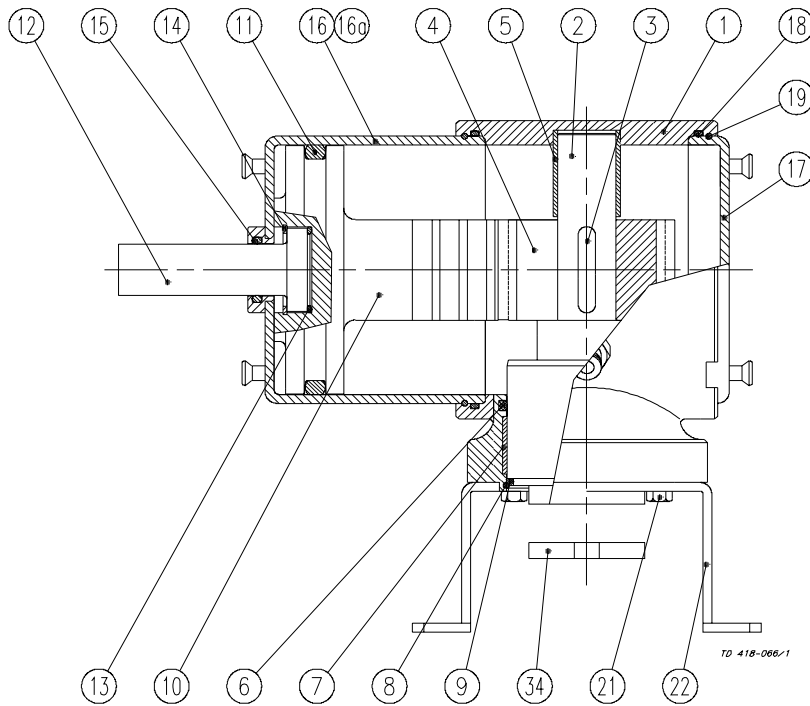

Telescope indication (type 632)

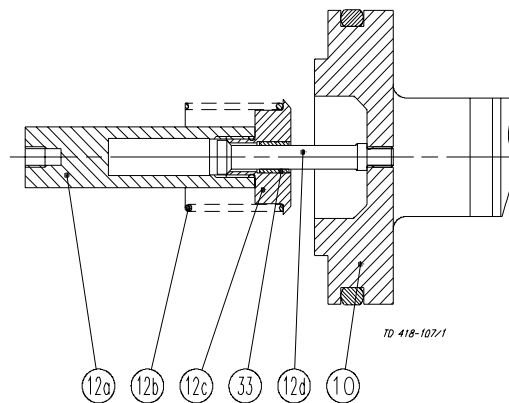

Drawing/Parts list

The drawings and the parts list include all items.

The items are identical with the items in the Spare Parts List.

When ordering spare parts, please use the Spare Parts List!

Parts list Actuator type 630

32

Item	Quant.	Denomination
1	1	Chassis
2	1	Spindle
3	1	Wedge
4	1	Gear wheel
5	1	Bearing
6 Δ	1	O-ring
7 Δ	1	Guide ring
8 Δ	1	Bearing
9	1	Lock ring
10	1	Piston
	2	Piston (type 631, sizes 80-101.6)
	2	Piston (type 632, sizes 80-101.6)
11 Δ	1	O-ring
	2	O-ring
	3	O-ring (type 633, sizes 25-76.1)
	4	O-ring (type 633, sizes 89-101.6)
12	1	Indication stem
a	1	Indication stem for telescope indication
b	1	Spring for telescope indication
c	1	Screw for telescope indication
d	1	Extension stem for telescope indication
13 Δ	1	O-ring
14	1	Circlip
15 Δ	1	O-ring
16	1	Cylinder
	2	Cylinder (type 630, sizes 63-76.1)
	2	Cylinder (type 633, sizes 89-101.6)
a	1	Cylinder for indication
17	1	Cylinder
18 Δ	2	O-ring
19	2	Lock wire
20	1	Bonnet
21	4	Screw
22	1	Spring (type 630, sizes 25-51)
	2	Spring (type 630, sizes 63-76)
23	1	Lock wire (type 630, sizes 25-51)
	2	Lock wire (type 630, sizes 63-76.1)
24	1	Flange
25	1	Flange for indication
26	1	Cylinder lid
a	2	Screw
27	1	Screw for indication stem
28	1	Auxiliary cylinder (type 633, sizes 25-76.1)
	2	Auxiliary cylinder (type 633, sizes 89-101.6)
29	1	Auxiliary piston (type 633, sizes 25-76.1)
	2	Auxiliary piston (type 633, sizes 89-101.6)
30 Δ	1	O-ring (type 633, sizes 25-76.1)
	2	O-ring (type 633, sizes 89-101.6)
31	1	Lock wire (type 633, sizes 25-76.1)
	2	Lock wire (type 633, sizes 89-101.6)
32	1	Air fitting (type 630)
	2	Air fitting (type 631, 632)
	3	Air fitting (type 633, sizes 25-76.1)
	5	Air fitting (type 633, sizes 89-101.6)
33	1	Guide for indication
34	1	Spindle extension (only for size 25)

Δ : Recommended Spare Parts.

This page shows an exploded drawing of KOLTEK.

The drawing includes all items of the actuator.
They are identical with the items in the Spare Parts List.

Exploded drawing

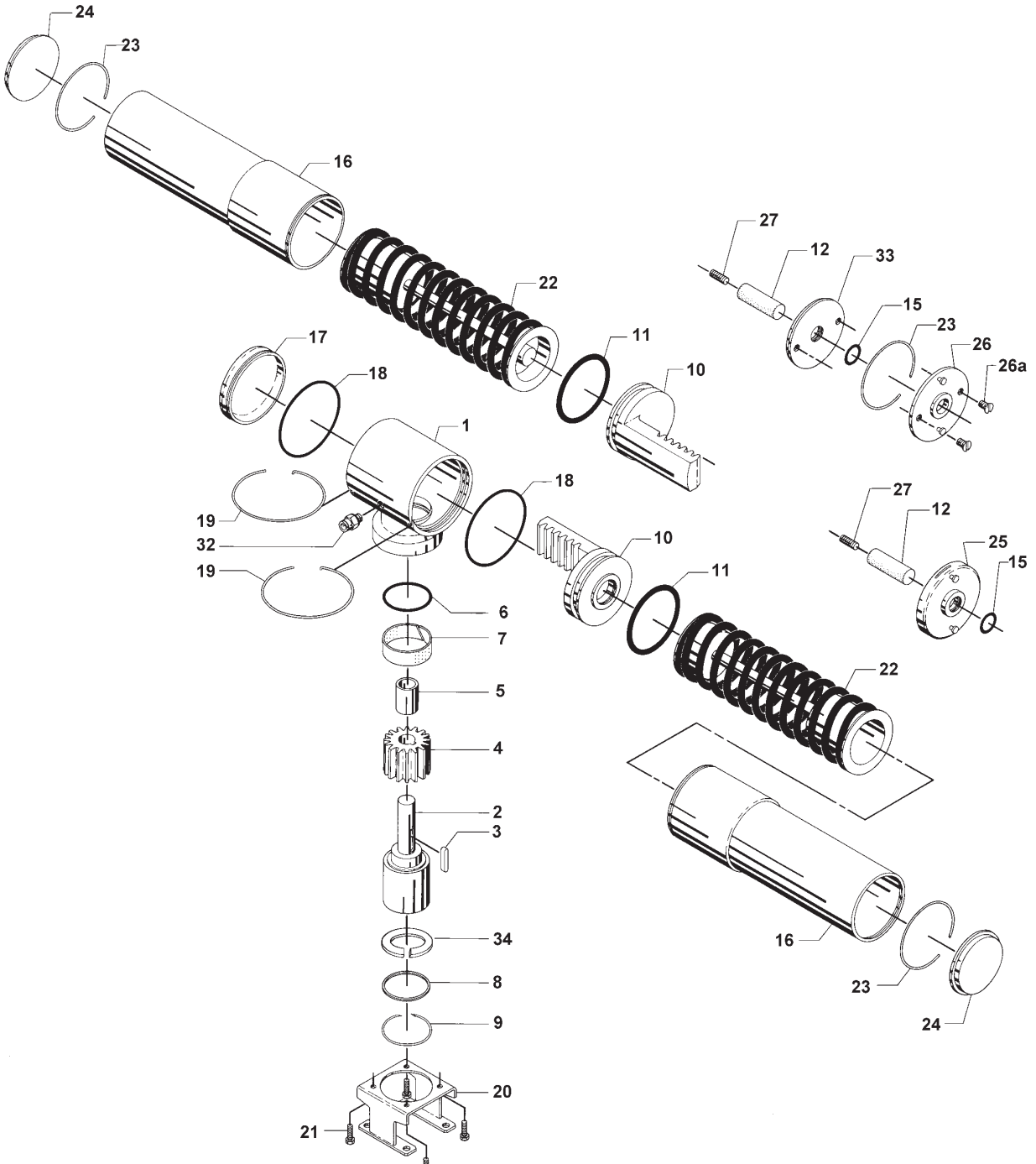

Drawing/Parts list

The drawings and the parts list include all items.

The items are identical with the items in the Spare Parts List.

When ordering spare parts, please use the Spare Parts List!

Parts list Actuator type 630

34

Item	Quant.	Denomination
1	1	Chassis
2	1	Spindle
3	1	Wedge
4	1	Gear wheel
5	1	Bearing
6 Δ	1	O-ring
7 Δ	1	Guide ring
8 Δ	1	Bearing
9	1	Lock ring
10	1	Piston
	2	Piston (type 631, sizes 80-101.6)
	2	Piston (type 632, sizes 80-101.6)
11 Δ	1	O-ring
	2	O-ring
	3	O-ring (type 633, sizes 25-76.1)
	4	O-ring (type 633, sizes 89-101.6)
12	1	Indication stem
a	1	Indication stem for telescope indication
b	1	Spring for telescope indication
c	1	Screw for telescope indication
d	1	Extension stem for telescope indication
13 Δ	1	O-ring
14	1	Circlip
15 Δ	1	O-ring
16	1	Cylinder
	2	Cylinder (type 630, sizes 63-76.1)
	2	Cylinder (type 633, sizes 89-101.6)
a	1	Cylinder for indication
17	1	Cylinder
18 Δ	2	O-ring
19	2	Lock wire
20	1	Bonnet
21	4	Screw
22	1	Spring (type 630, sizes 25-51)
	2	Spring (type 630, sizes 63-76)
23	1	Lock wire (type 630, sizes 25-51)
	2	Lock wire (type 630, sizes 63-76.1)
24	1	Flange
25	1	Flange for indication
26	1	Cylinder lid
a	2	Screw
27	1	Screw for indication stem
28	1	Auxiliary cylinder (type 633, sizes 25-76.1)
	2	Auxiliary cylinder (type 633, sizes 89-101.6)
29	1	Auxiliary piston (type 633, sizes 25-76.1)
	2	Auxiliary piston (type 633, sizes 89-101.6)
30 Δ	1	O-ring (type 633, sizes 25-76.1)
	2	O-ring (type 633, sizes 89-101.6)
31	1	Lock wire (type 633, sizes 25-76.1)
	2	Lock wire (type 633, sizes 89-101.6)
32	1	Air fitting (type 630)
	2	Air fitting (type 631, 632)
	3	Air fitting (type 633, sizes 25-76.1)
	5	Air fitting (type 633, sizes 89-101.6)
33	1	Guide for indication
34	1	Spindle extension (only for size 25)

Δ : Recommended Spare Parts.

The drawing below shows KOLTEK actuator.

The items refer to the parts list on the opposite part of the page.

Drawing

Type 630
(sizes 63.5-76.1 mm/DN65)

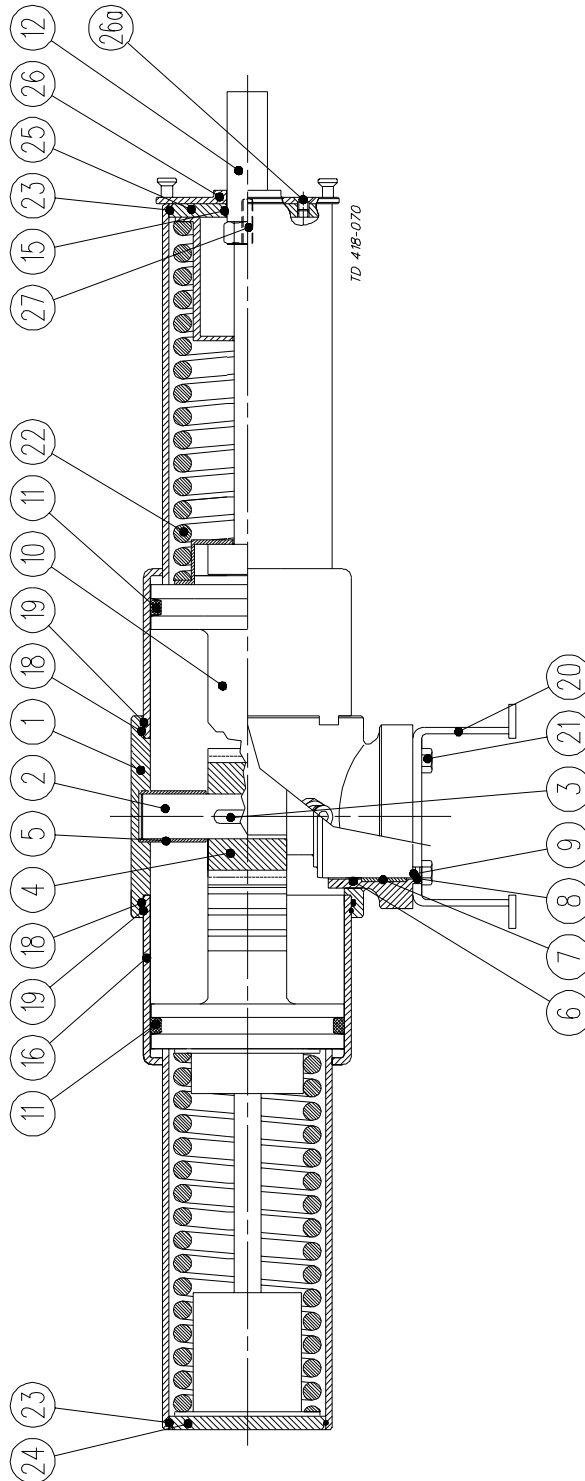

Drawing/Parts list

The drawings and the parts list include all items.

The items are identical with the items in the Spare Parts List.

When ordering spare parts, please use the Spare Parts List!

Parts list Actuator type 633

36

Item	Quant.	Denomination
1	1	Chassis
2	1	Spindle
3	1	Wedge
4	1	Gear wheel
5	1	Bearing
6 Δ	1	O-ring
7 Δ	1	Guide ring
8 Δ	1	Bearing
9	1	Lock ring
10	1	Piston
	2	Piston (type 631, sizes 80-101.6)
	2	Piston (type 632, sizes 80-101.6)
11 Δ	1	O-ring
	2	O-ring
	3	O-ring (type 633, sizes 25-76.1)
	4	O-ring (type 633, sizes 89-101.6)
12	1	Indication stem
a	1	Indication stem for telescope indication
b	1	Spring for telescope indication
c	1	Screw for telescope indication
d	1	Extension stem for telescope indication
13 Δ	1	O-ring
14	1	Circlip
15 Δ	1	O-ring
16	1	Cylinder
	2	Cylinder (type 630, sizes 63-76.1)
	2	Cylinder (type 633, sizes 89-101.6)
a	1	Cylinder for indication
17	1	Cylinder
18 Δ	2	O-ring
19	2	Lock wire
20	1	Bonnet
21	4	Screw
22	1	Spring (type 630, sizes 25-51)
	2	Spring (type 630, sizes 63-76)
23	1	Lock wire (type 630, sizes 25-51)
	2	Lock wire (type 630, sizes 63-76.1)
24	1	Flange
25	1	Flange for indication
26	1	Cylinder lid
a	2	Screw
27	1	Screw for indication stem
28	1	Auxiliary cylinder (type 633, sizes 25-76.1)
	2	Auxiliary cylinder (type 633, sizes 89-101.6)
29	1	Auxiliary piston (type 633, sizes 25-76.1)
	2	Auxiliary piston (type 633, sizes 89-101.6)
30 Δ	1	O-ring (type 633, sizes 25-76.1)
	2	O-ring (type 633, sizes 89-101.6)
31	1	Lock wire (type 633, sizes 25-76.1)
	2	Lock wire (type 633, sizes 89-101.6)
32	1	Air fitting (type 630)
	2	Air fitting (type 631, 632)
	3	Air fitting (type 633, sizes 25-76.1)
	5	Air fitting (type 633, sizes 89-101.6)
33	1	Guide for indication
34	1	Spindle extension (only for size 25)

Δ : Recommended Spare Parts.

This page shows an exploded drawing of KOLTEK.

The drawing includes all items of the actuator.
They are identical with the items in the Spare Parts List.

Exploded drawing

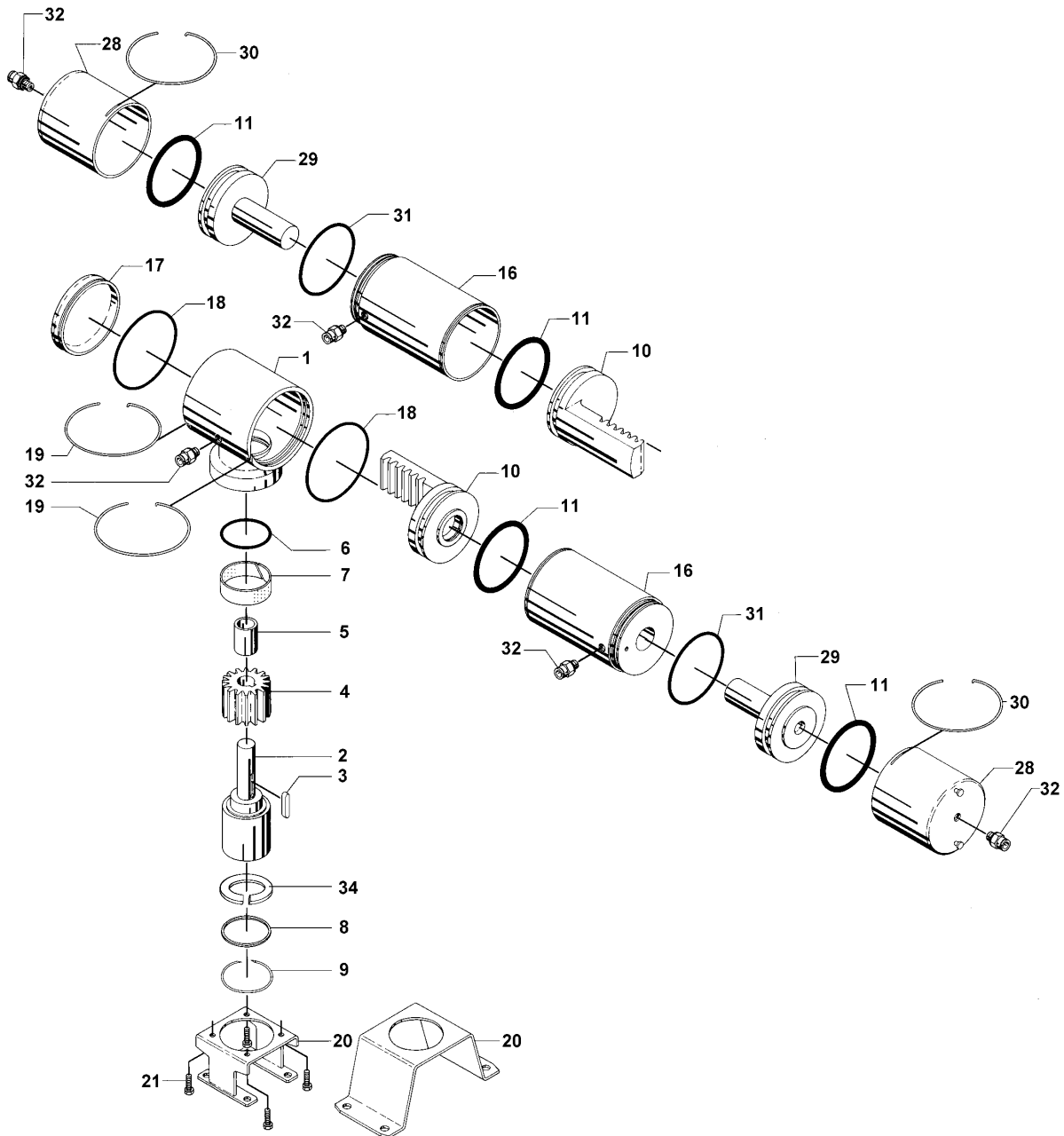

Drawing/Parts list

The drawings and the parts list include all items.

The items are identical with the items in the Spare Parts List.

When ordering spare parts, please use the Spare Parts List!

Parts list Actuator type 633

38

Item	Quant.	Denomination
1	1	Chassis
2	1	Spindle
3	1	Wedge
4	1	Gear wheel
5	1	Bearing
6 Δ	1	O-ring
7 Δ	1	Guide ring
8 Δ	1	Bearing
9	1	Lock ring
10	1	Piston
	2	Piston (type 631, sizes 80-101.6)
	2	Piston (type 632, sizes 80-101.6)
11 Δ	1	O-ring
	2	O-ring
	3	O-ring (type 633, sizes 25-76.1)
	4	O-ring (type 633, sizes 89-101.6)
12	1	Indication stem
a	1	Indication stem for telescope indication
b	1	Spring for telescope indication
c	1	Screw for telescope indication
d	1	Extension stem for telescope indication
13 Δ	1	O-ring
14	1	Circlip
15 Δ	1	O-ring
16	1	Cylinder
	2	Cylinder (type 630, sizes 63-76.1)
	2	Cylinder (type 633, sizes 89-101.6)
a	1	Cylinder for indication
17	1	Cylinder
18 Δ	2	O-ring
19	2	Lock wire
20	1	Bonnet
21	4	Screw
22	1	Spring (type 630, sizes 25-51)
	2	Spring (type 630, sizes 63-76)
23	1	Lock wire (type 630, sizes 25-51)
	2	Lock wire (type 630, sizes 63-76.1)
24	1	Flange
25	1	Flange for indication
26	1	Cylinder lid
a	2	Screw
27	1	Screw for indication stem
28	1	Auxiliary cylinder (type 633, sizes 25-76.1)
	2	Auxiliary cylinder (type 633, sizes 89-101.6)
29	1	Auxiliary piston (type 633, sizes 25-76.1)
	2	Auxiliary piston (type 633, sizes 89-101.6)
30 Δ	1	O-ring (type 633, sizes 25-76.1)
	2	O-ring (type 633, sizes 89-101.6)
31	1	Lock wire (type 633, sizes 25-76.1)
	2	Lock wire (type 633, sizes 89-101.6)
32	1	Air fitting (type 630)
	2	Air fitting (type 631, 632)
	3	Air fitting (type 633, sizes 25-76.1)
	5	Air fitting (type 633, sizes 89-101.6)
33	1	Guide for indication
34	1	Spindle extension (only for size 25)

Δ : Recommended Spare Parts.

The drawing below shows KOLTEK actuator.

The items refer to the parts list on the opposite part of the page.

Drawing

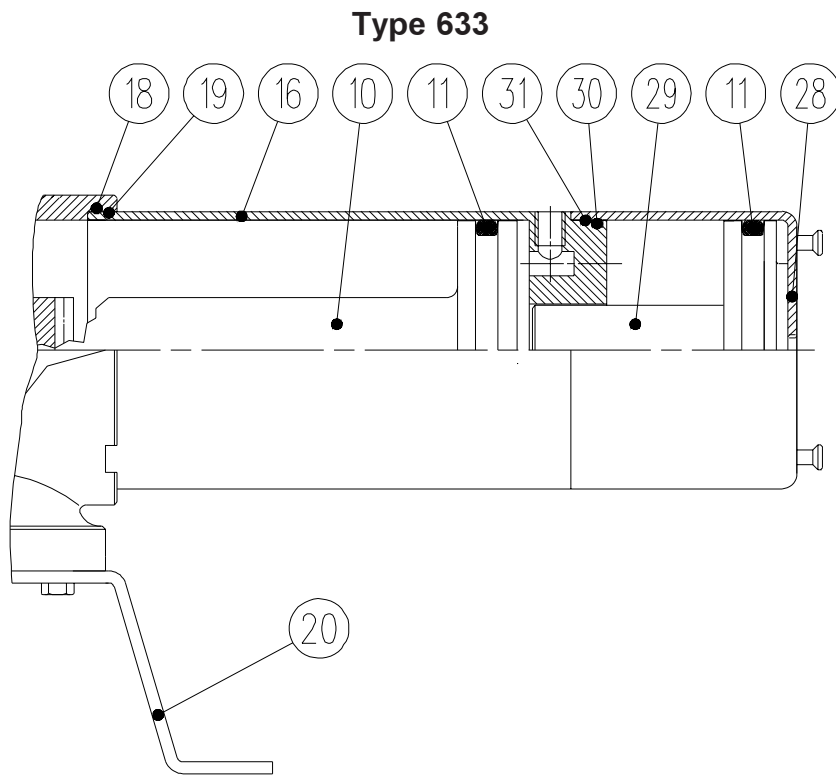

TD 418-071

How to contact Alfa Laval

Contact details for all countries are continually updated on our website. Please visit www.alfalaval.com to access the information direct.