

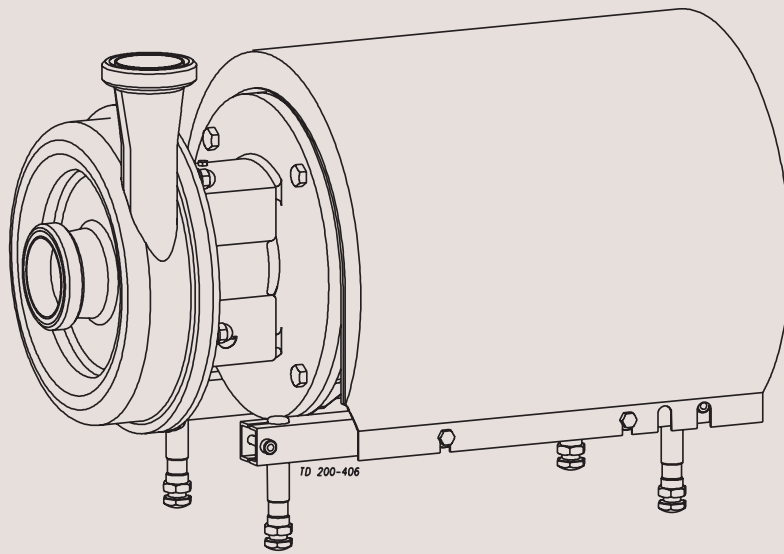

Operating Manual

LKHI Centrifugal Pump for 16 bar Inlet Pressure



Declaration of Conformity

The designating company

Alfa Laval

Company Name

6000 Kolding

Address

+45 79 32 22 00

Phone No.

hereby declare that

**CENTRIFUGAL PUMP
FOR 16 BAR INLET PRESSURE**

Denomination

LKHI

Type

Year

is in conformity with the following directives with amendments:

- Low Voltage Directive 73/23/EEC
- EMC Directive 89/336/EEC
- Machinery Directive 89/392/EEC

Bjarne Søndergaard

Name

Vice President, R & D

Title

Alfa Laval

Company

B. Søndergaard

Signature

Designation

CE

Table of contents

This manual is divided into main sections. - See below.

Safety

1. Important information	2
2. Warning signs	2
3. Safety precautions	3

Installation

1. Unpacking/Delivery	4
2. Installation	5
3. Pre-use check	6

Operation

1. Operation/Control	7
2. Fault finding	8
3. Recommended cleaning	9

Maintenance

1. General maintenance	10
2. Dismantling of pump/shaft seal	12
3. Assembly of pump/shaft seal	14

Technical data

1. Technical data	16
-------------------------	----

Drawings/Parts list

1. Parts list	18+20
2. Exploded drawing	19
3. Drawing	21

Appendix

Spare Parts

Safety

Unsafe practices and other important information are emphasized in this manual.

Warnings are emphasized by means of special signs.

1. Important information

Always read the manual before using the pump!

2

- WARNING!** : Indicates that special procedures **must** be followed to avoid severe personal injury.
- CAUTION!** : Indicates that special procedures **must** be followed to avoid damage to the pump.
- NOTE!** : Indicates important information to simplify practices or to make them clearer.

2. Warning signs



: General warning.



: Dangerous electrical voltage.



: Caustic agents.

All warnings in the manual are summarized on this page.

Pay special attention to the instructions below so that severe personal injury and/or damage to the pump are avoided.

3. Safety precautions

Installation:



- : **Always** read the technical data thoroughly (see page 16).



- : **Always** have the pump electrically connected by authorized personnel (see the motor instructions).



- : **Pump without impeller screw:**
 - **Always** remove the impeller before checking the direction of rotation.
 - **Never** start the pump in the wrong direction of rotation with the impeller fitted.
- : **Pump with impeller screw:**
 - **Never** start in the wrong direction of rotation with liquid in the pump.

Operation:



- : **Always** read the technical data thoroughly (see page 16).



- : **Never** touch the pump or the pipelines when pumping hot liquids or when sterilizing.



- : **Never** run the pump with both the suction side and the pressure side blocked.



- : **Always** handle lye and acid with great care.

Maintenance:



- : **Always** read the technical data thoroughly (see page 16).



- : **Always** disconnect the power supply when servicing the pump.



- :
 - **Never** service the pump when it is hot.
 - **Never** service the pump with pump and pipelines under pressure.

Installation

The instruction manual is part of the delivery. Study the instructions carefully.

The standard delivery does not include the test certificate. This can be supplied on request.

1. Unpacking/Delivery

1

CAUTION!

We cannot be held responsible for incorrect unpacking.

Check the delivery for:

1. Complete pump.
2. Delivery note.
3. Instruction manual.
4. Motor instructions.
5. Test certificate, IF ORDERED!

2

Remove packing materials!

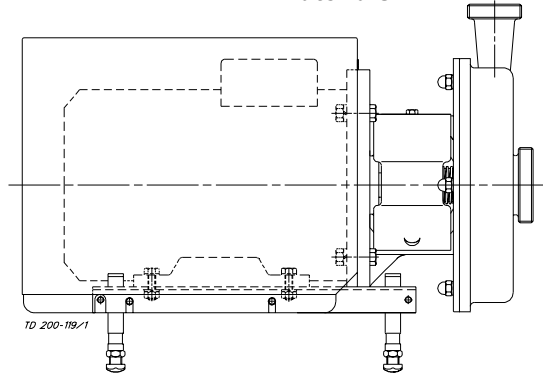

Remove possible packing materials from the inlet and the outlet.

3

Inspection!

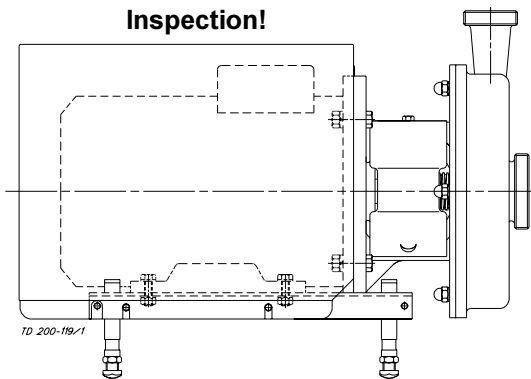

Inspect the pump for visible transport damage.

4

Caution!

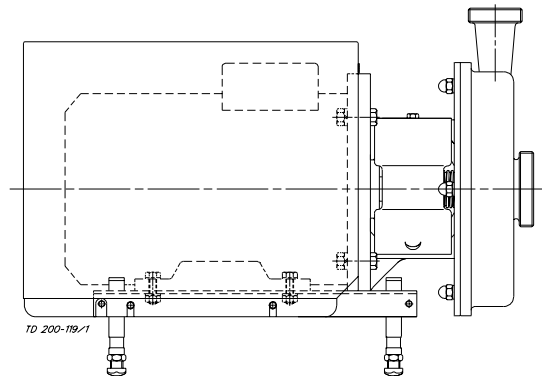

Avoid damaging the inlet and the outlet.

5

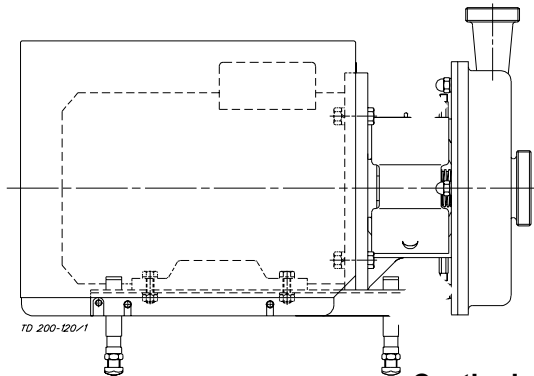

Avoid damaging the connections for flushing liquid, if supplied.

6

Remove the shroud before lifting!

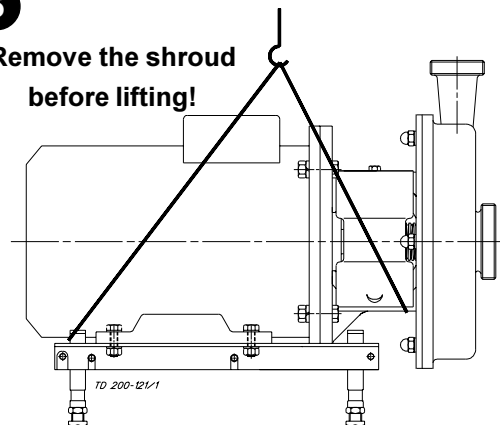

Always remove the shroud, if fitted, before lifting the pump.

Study the instructions carefully and pay special attention to the warnings!

Always check the direction of rotation of the impeller before operation.
- See pre-use check on page 6.

2. Installation

1

! Always read the technical data thoroughly (see page 16).



Always have the pump electrically connected by authorized personnel (see the motor instructions).

CAUTION!

We cannot be held responsible for incorrect installation.

2

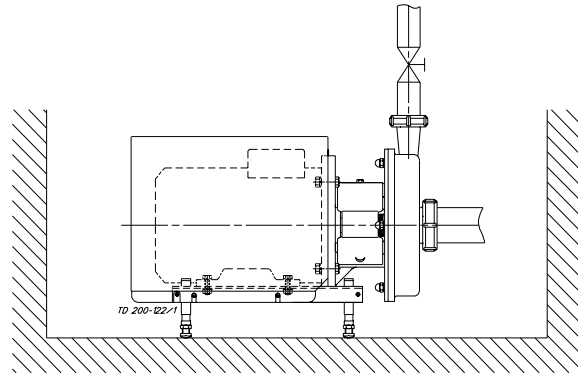

Ensure that there is sufficient clearance around the pump (min. 0.5 m).

3

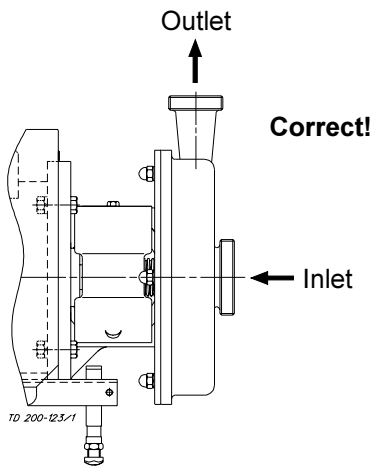

Check that the flow direction is correct.

4

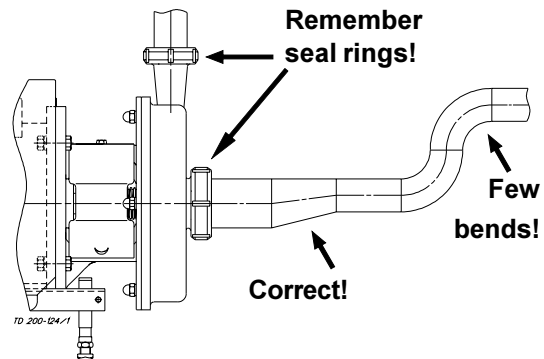

1. Ensure that the pipelines are routed correctly.
2. Ensure that the connections are tight.

5

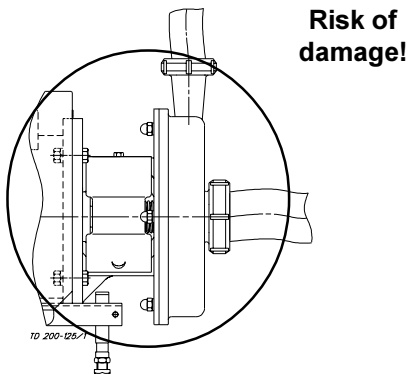

Avoid stressing the pump.
Pay special attention to:

- Vibrations.
- Thermal expansion of the tubes.
- Excessive welding.
- Overloading of the pipelines.

Installation

6

Study the instructions carefully and pay special attention to the warnings!
The pump is without impeller screw as standard but can be supplied with one.

Check the direction of rotation of the impeller before operation.
- See the indication label on the pump.

3. Pre-use check - Pump without impeller screw

1

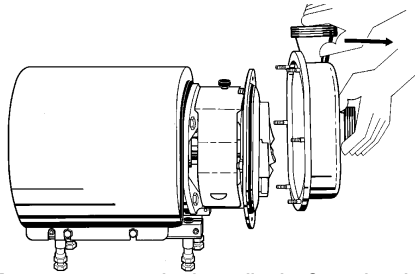

- **Always** remove the impeller before checking the direction of rotation.
- **Never** start the pump in the wrong direction of rotation with the impeller fitted.

1. Unscrew cap nuts (28) and remove washers (29) and pump casing (45).
2. Remove impeller (39) and the rotating part of the shaft seal (see also instruction 4 and 5 on page 12).

2

See indication label!

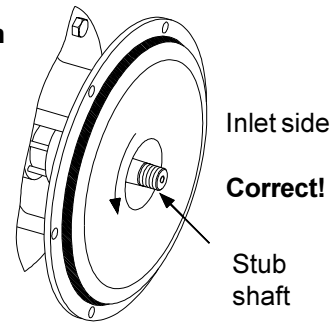

TD 223-008

1. Start and stop the motor momentarily.
2. Ensure that the direction of rotation of stub shaft (9) is **anticlockwise** as viewed from the inlet side.

3

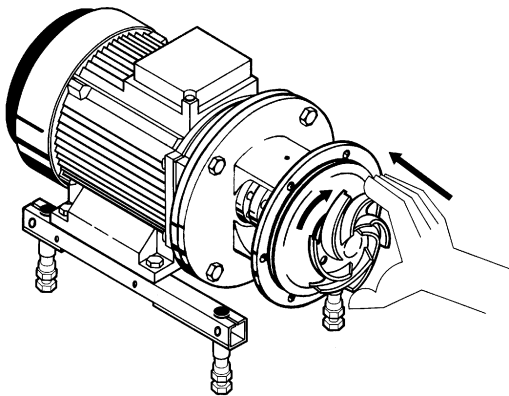

Fit and tighten impeller (39) and shaft seal.

4

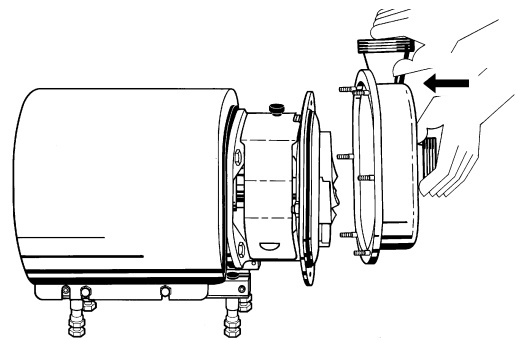

1. Fit pump casing (45) on back plate (30).
2. Fit washers (29) and cap nuts (28) and tighten.

3. Pre-use check - Pump with impeller screw

CAUTION!

Never start in the wrong direction of rotation with liquid in the pump.

1. Start and stop the motor momentarily.
2. Ensure that the direction of rotation of the motor fan is **clockwise** as viewed from the rear end of the motor.

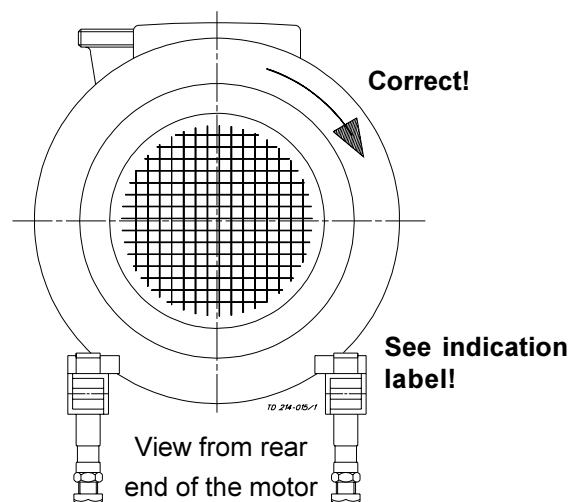

Study the instructions carefully and pay special attention to the warnings!

The pump is fitted with a warning label indicating correct throttling.

1. Operation/Control

1

 **Always** read the technical data thoroughly (see page 16).

CAUTION!

We cannot be held responsible for incorrect operation/control.

2

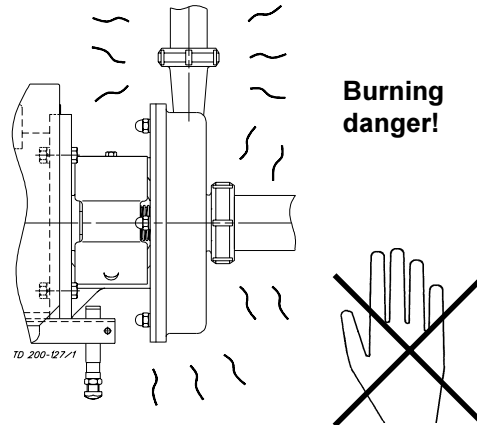

 **Never** touch the pump or the pipelines when pumping hot liquids or when sterilizing.

3

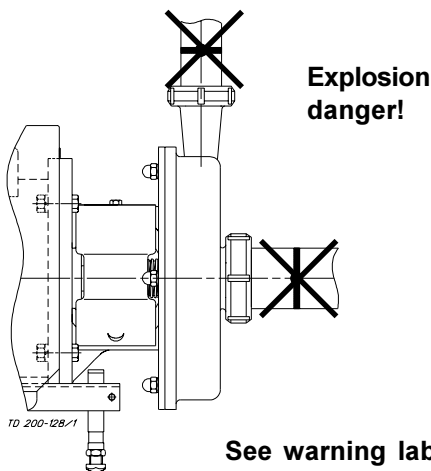

 **Never** run the pump with both the suction side and the pressure side blocked.

4

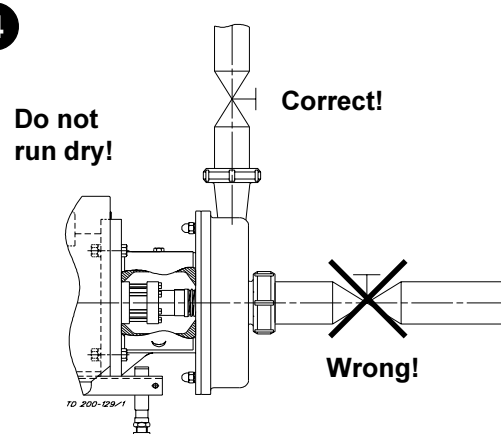

CAUTION!

- The shaft seal must **not** run dry.
- **Never** throttle the inlet side.

5

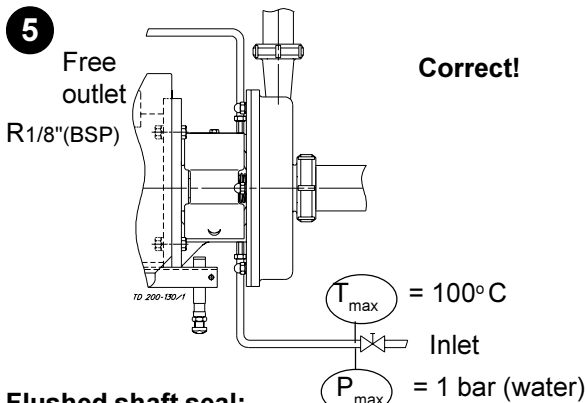

Flushed shaft seal:

1. Connect the inlet of the flushing liquid correctly.
2. Regulate the water and steam supply correctly.
3. Observe the steam data.

6

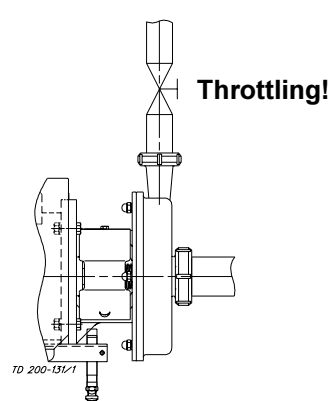

Control:

Reduce the capacity and the power consumption by means of:

- Throttling the pressure side of the pump.
- Reducing the impeller diameter.
- Speed control of the motor.

Pay attention to possible faults.

Study the instructions carefully.

2. Fault finding

NOTE!

Study the maintenance instructions carefully before replacing worn parts. - See page 10!

Problem	Cause/result	Repair
Overloaded motor	<ul style="list-style-type: none"> - Pumping of viscous liquids - Pumping of liquids with high density - Low outlet pressure (counter pressure) - Lamination of precipitates from the liquid 	<ul style="list-style-type: none"> - Larger motor or smaller impeller - Higher counter pressure (throttling) - Frequent cleaning
Cavitation: <ul style="list-style-type: none"> - Damage - Pressure reduction (sometimes to zero) - Increasing of the noise level 	<ul style="list-style-type: none"> - Low inlet pressure - High liquid temperature 	<ul style="list-style-type: none"> - Increase the inlet pressure - Reduce the liquid temperature - Reduce the pressure drop before the pump
Leaking shaft seal	<ul style="list-style-type: none"> - Dry run (See page 7) - Incorrect rubber grade - Abrasive particles in the liquid 	<p>Replace: All wearing parts (See page 10)</p> <p>If necessary:</p> <ul style="list-style-type: none"> - Select a different rubber grade - Select stationary and rotating seal ring in Silicon Carbide/ Silicon Carbide
Leaking seals	Incorrect rubber grade	Replace with seals of a different rubber grade

The pump is designed for cleaning in place (CIP).
CIP = Cleaning In Place.

Study the instructions carefully and pay special attention to the warnings!

NaOH = Caustic Soda.

HNO₃ = Nitric acid.

3. Recommended cleaning

1

Caustic danger!



Always use rubber gloves!



Always use protective goggles!



Always handle lye and acid with great care.

3

Examples of cleaning agents:

Use clean water, free from chlorides.

- 1% by weight NaOH at 70° C.

1 kg NaOH	+	100 l water	= Cleaning agent.
-----------	---	-------------	-------------------

2.2 l 33% NaOH	+	100 l water	= Cleaning agent.
----------------	---	-------------	-------------------

- 0.5% by weight HNO₃ at 70° C.

0.7 l 53% HNO ₃	+	100 l water	= Cleaning agent.
----------------------------	---	-------------	-------------------

5

Always rinse!



Always rinse well with clean water after the cleaning.

2

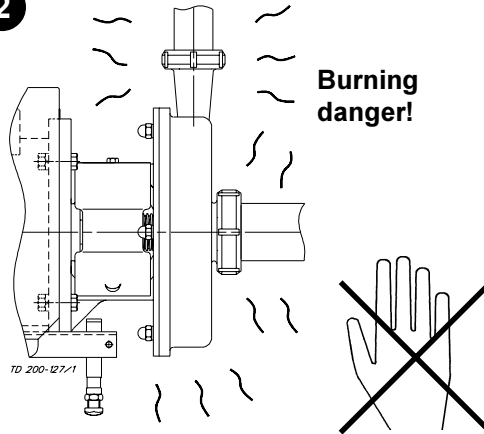

Never touch the pump or the pipelines when sterilizing.

4

- Avoid excessive concentration of the cleaning agent

⇒ **Dose gradually!**

- Adjust the cleaning flow to the process

Milk sterilization/viscous liquids

⇒ **Increase the cleaning flow!**

6

NOTE!

The cleaning agents must be stored/disposed of in accordance with current rules/directives.

Maintenance

10

Maintain the pump regularly.
Study the instructions carefully and pay special attention to the warnings!

Always keep spare shaft seals and rubber seals in stock.
See separate motor instructions.

1. General maintenance

1

 **Always** read the technical data thoroughly (see page 16).

 **Always** disconnect the power supply when servicing the pump.

NOTE!

All scrap must be stored/disposed of in accordance with current rules/directives.

2

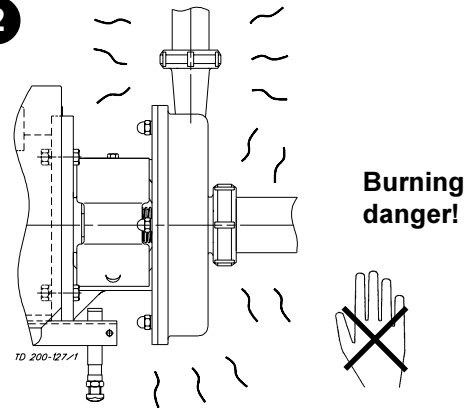

 **Never** service the pump when it is hot.

3

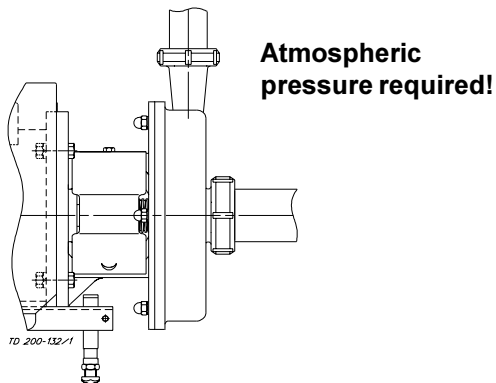

 **Never** service the pump with pump and pipelines under pressure.

4

CAUTION!

Fit the electrical connections correctly if they have been removed from the motor during service (see pre-use check on page 6).

Pay special attention to the warnings!

Ordering spare parts

- Contact the Sales Department.
- Order from the Spare Parts List.

Recommended spare parts: Service kits (see Spare Parts List).

Maintain the pump regularly.
 Study the instructions carefully.
 Always keep spare shaft seals and rubber seals in stock.

See separate motor instructions.
 Check the pump for smooth operation after service.

1. General maintenance

	Shaft seal	Rubber seals	Motor bearings
Preventive maintenance	Replace after 12 months: (one-shift) Complete shaft seal	Replace when replacing the shaft seal	
Maintenance after leakage (leakage normally starts slowly)	Replace at the end of the day: Complete shaft seal	Replace when replacing the shaft seal	
Planned maintenance	- Regular inspection for leakage and smooth operation - Keep a record of the pump - Use the statistics for planning of inspections Replace after leakage: Complete shaft seal	Replace when replacing the shaft seal	Yearly inspection is recommended - Replace complete bearing if worn - Ensure that the bearing is axially locked. (See motor instructions)
Lubrication	Before fitting Lubricate the O-rings with silicone grease or silicone oil	Before fitting Silicone grease or silicone oil	Motors without grease nipples are permanently lubricated and therefore need no lubrication. Lubrication intervals for motors with grease nipples are shown on information plate on the motor. The lubrication intervals are based on 80°C bearing temperature. The values should be halved for every 15°C increase in the bearing temperature. NOTE! Motors with grease nipples should be lubricated before operating the first time!

Pre-use check

CAUTION!

- Fit the electrical connections correctly if they have been removed from the motor during service. (See pre-use check on page 6).
 - **Pay special attention to the warnings!**
1. Start and stop the motor momentarily.
 2. Ensure that the pump operates smoothly.

Maintenance

12

Study the instructions carefully.
The items refer to the drawings and the parts list on the pages 18-21.

Handle scrap correctly.
*: Relates to the shaft seal.

2. Dismantling of pump/Dismantling of shaft seal

1

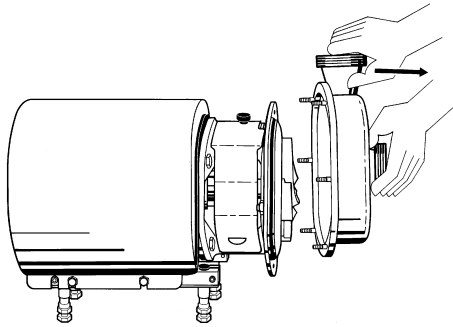

Unscrew cap nuts (28) and remove washers (29) and pump casing (45).

2

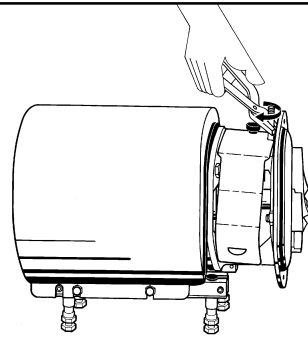

Flushed shaft seal:
Unscrew tubes (23) using a spanner.

3

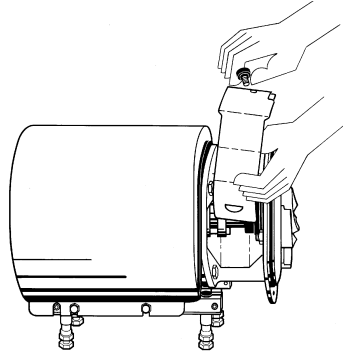

Remove screw (14), washer (15) and safety guard (16).

4

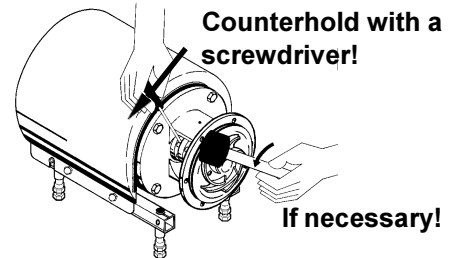

1. If fitted, unscrew impeller screw (41) and pull off O-ring (42).
2. Remove impeller (39).
3. If necessary, loosen the impeller by knocking gently on the impeller vanes.

5

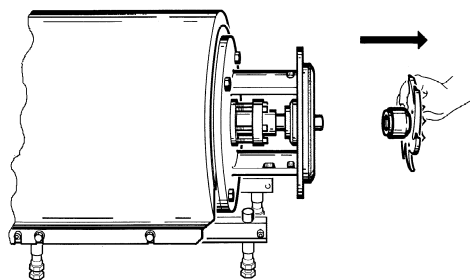

Pull out impeller (39) and the rotating part of the shaft seal.

6

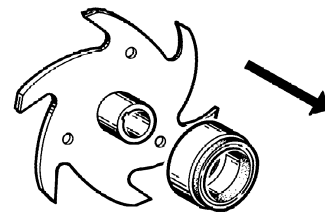

Remove space ring (33) and the rotating part of the shaft seal from impeller (39).

7

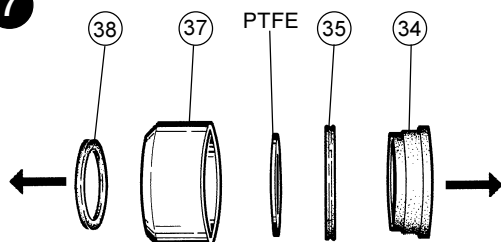

Separate rotating seal ring (34) and quad rings (35, 38), from rotating seal housing (37).

8

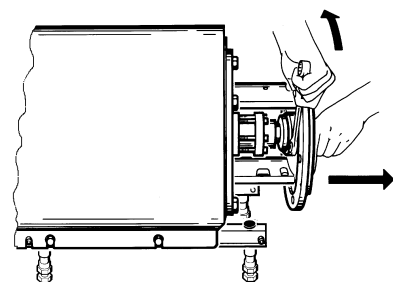

1. Unscrew nuts (19) and remove washers (20) and back plate (30).
2. Pull off O-ring (43) from the back plate.

Study the instructions carefully.
The items refer to the drawings and the parts list on the pages 18-21.

Handle scrap correctly.
*: Relates to the shaft seal.

2. Dismantling of pump/Dismantling of shaft seal

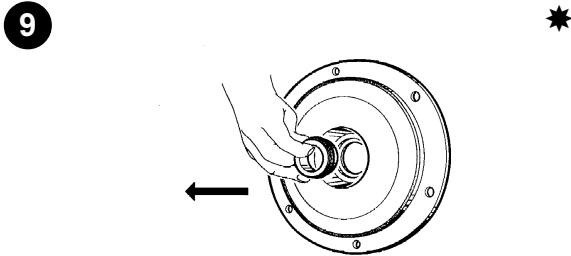

1. Pull out stationary seal ring (32).
2. Remove O-ring (31) from the stationary seal ring.

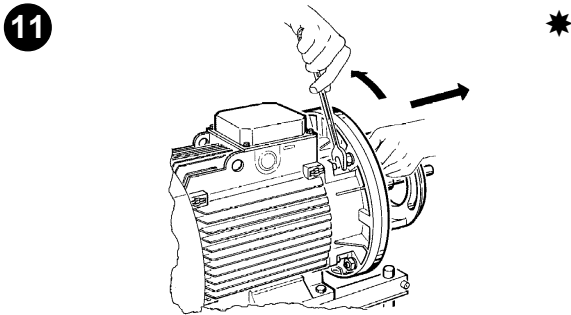

1. Remove shroud (2).
2. Unscrew nuts (7) and remove washers (6), screws (18) and adaptor (17).

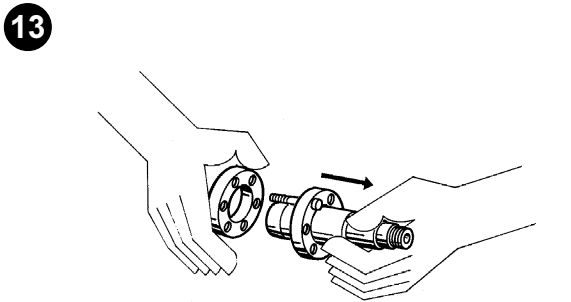

Separate screws (13), washers (13a) and compression rings (8, 12).

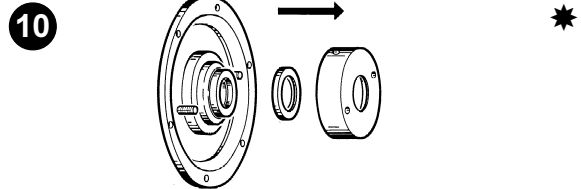

Flushed shaft seal:

1. Remove screws (22) and seal housing (21).
2. Pull out lip seal (24) and O-ring (26) from the seal housing.
3. Slide off sleeve (27) from stub shaft (9).
4. Remove O-ring (25) from the sleeve.

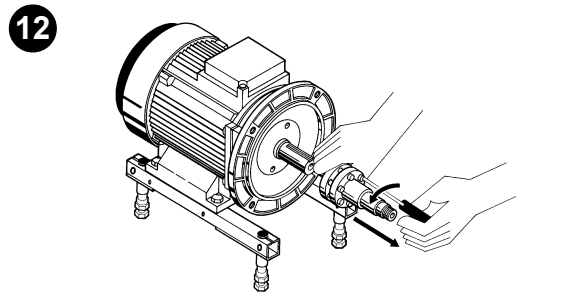

1. Loosen screws (13).
2. Slide off stub shaft (9) together with compression rings (8, 12).

Maintenance

Study the instructions carefully.
The items refer to the drawings and the parts list on the pages 18-21.

Lubricate the rubber seals before fitting them.
*: Relates to the shaft seal.

3. Assembly of pump/Assembly of shaft seal

1

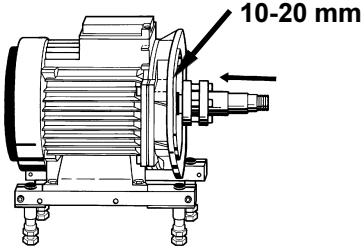

10-20 mm

1. Fit compression rings (8, 12), washers (13a) and screws (13) on stub shaft (9).
2. Slide the stub shaft onto the motor shaft.
3. Check the clearance between the end of the stub shaft and the motor flange (10-20 mm).

2

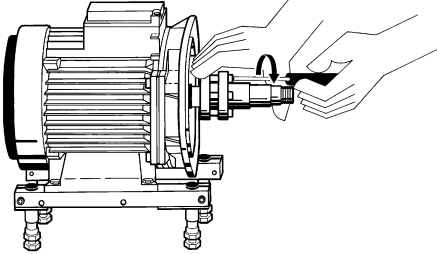

1. Tighten screws (13) lightly and evenly.
2. Ensure that stub shaft (9) can be moved on the motor shaft.

3

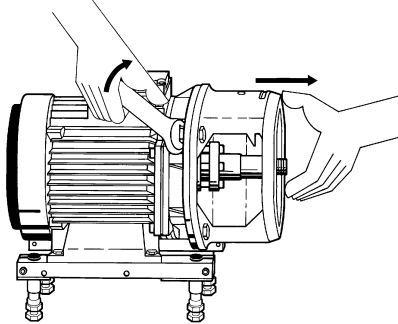

Fit adaptor (17), screws (18), washers (6) and nuts (7) and tighten.

4

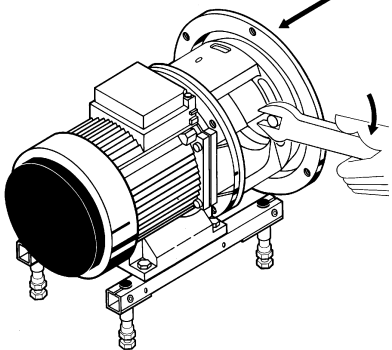

Fit back plate (30), washers (20) and nuts (19) and tighten.

5

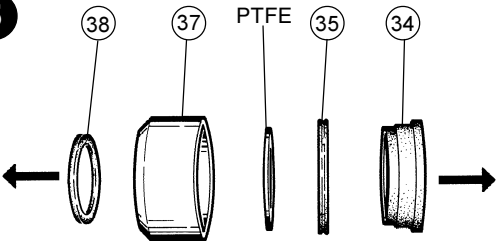

38 37 PTFE 35 34 *

Assemble the rotating part of the shaft seal as shown above.

CAUTION!
Ensure that the driver in the rotating seal housing (37) enters the notch in the rotating seal ring.

6

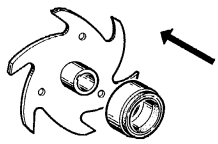

Fit the rotating part of the shaft seal and the space ring (33) on the impeller (39).

7

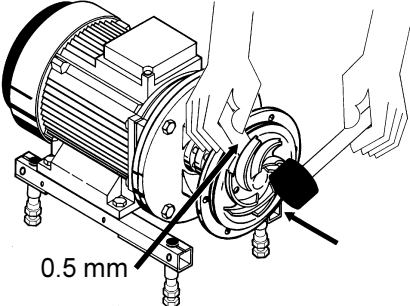

0.5 mm *

1. Fit impeller (39) on stub shaft (9) by rotating clockwise.
2. Ensure that the clearance between the impeller and back plate (30) is 0.5 mm.

8

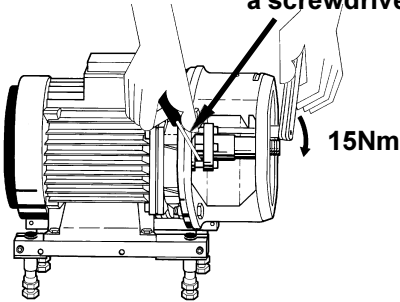

Counterhold with a screwdriver
15Nm *

1. Remove impeller (39) and back plate (30).
2. Tighten screws (13) evenly to 15 Nm.

Study the instructions carefully.
The items refer to the drawings and the parts list on the pages 18-21.

Lubricate the rubber seals before fitting them.
*: Relates to the shaft seal.

3. Assembly of pump/Assembly of shaft seal

9 *

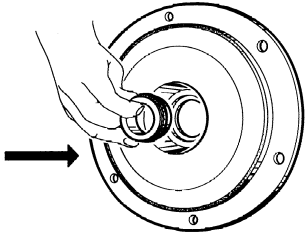

1. Slide O-ring (31) onto stationary seal ring (32).
2. Press the stationary seal ring into back plate (30).

10 *

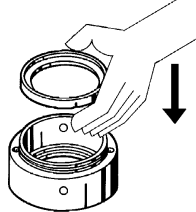

Flushed shaft seal:

1. Fit lip seal (24) and O-ring (26) in seal housing (21).
2. Fit the housing on back plate (30) and tighten the screws (22).
3. Slide sleeve (27) with O-ring (25) onto stub shaft (9).

11 *

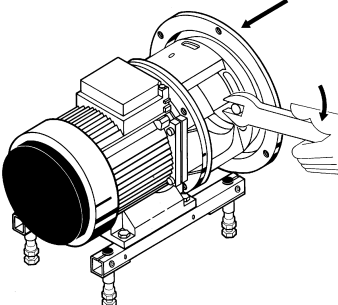

1. Fit back plate (30), washers (20) and nuts (19) and tighten.
2. Fit O-ring (43) on the back plate.

12

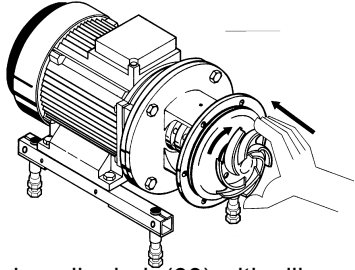

1. Lubricate impeller hub (39) with silicone grease or oil.
2. Screw the impeller onto stub shaft (9).
3. If used, fit O-ring (42) and impeller screw (41).

13

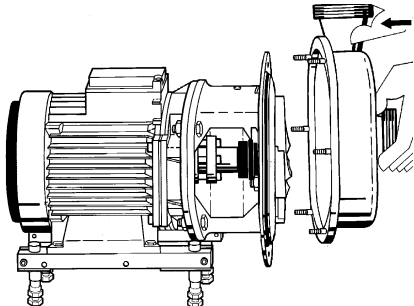

1. Fit pump casing (45).
2. Fit washers (29) and cap nuts (28) and tighten.

14

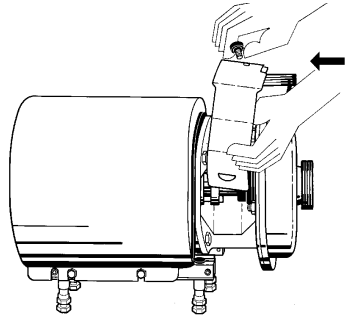

1. Mount shroud (2).
2. Position safety guard (16), washer (15) and screw (14) and tighten.

15

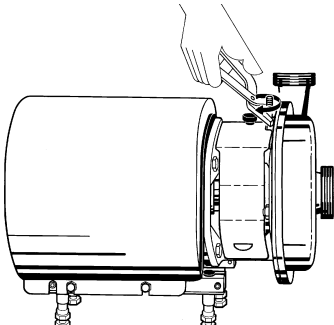

Flushed shaft seal:
Fit tubes (23) in seal housing (21).

Technical data

16

It is important to read the technical data carefully before installation, operation and maintenance.

Inform the personnel about the technical data.

1. Technical data

Data

Max. inlet pressure	1600 kPa (16 bar)
Temperature range	-10°C to +140°C (EPDM)
Noise level	60-80 dB (A)

Materials

Product wetted steel parts	AISI 316L
Other steel parts	AISI 304
Finish	Semi bright
Product wetted seals	EPDM (standard)
Other O-rings	EPDM
Alternative seals	Nitrile (NBR) and Fluorinated rubber (FPM)

Shaft seal

Seal types	Single internal or flushed seal
Max. water pressure (flushed seal)	Normally atmospheric (max. 1 bar)
Water consumption (flushed seal)	0.25 - 0.5 l/min.
Material, stationary seal ring	Silicon Carbide
Material, rotating seal ring	Carbon or Silicon Carbide
Material, Quad-/O-rings	EPDM (standard)
Material comb.	Silicon Carbide/Carbon or Silicon Carbide/Silicon Carbide

Motor

Foot-flanged motor acc. to IEC metric standard
 2 pole = 3000/3600 rpm. at 50/60 Hz
 IP55 (with drain hole sealed with plug), insulation class F

Motor types: - Standard motor with ball bearings
 - Special motor with a fixed angular-contact ball bearing on drive side

Inlet pressure (bar)	
0-10	10-16
Standard motor	Special motor

NOTE: The special motor **must** be ordered for inlet pressure 10-16bar

Voltage and frequency	$\left(\begin{array}{l} 3\sim, 50 \text{ Hz, } 220\text{-}240\text{VD}/380\text{-}420\text{VY} \leq 4 \text{ kW} \\ 3\sim, 60 \text{ Hz, } 250\text{-}280\text{V}\Delta/440\text{-}480\text{VY} \leq 4.6 \text{ kW} \\ 3\sim, 50 \text{ Hz, } 380\text{-}420\text{V}\Delta/660\text{VY} \geq 5.5 \text{ kW} \\ 3\sim, 60 \text{ Hz, } 440\text{-}480\text{V}\Delta \geq 6.3 \text{ kW} \end{array} \right)$
-----------------------------	--

Motor sizes (kW), 50 Hz, 380 DV	1.5, 2.2, 3.0, 4.0, 5.5, 7.5, 11.0, 15.0, 18.5, 22.0, 30.0
Motor sizes (kW), 60 Hz, 440 DV	1.75, 2.5, 3.5, 4.6, 6.4, 8.6, 12.5, 17.0 21.0, 25.0, 35.0



Drawing/Parts list

The drawing and the parts list include all items of the pump.

The items are identical with the items in the Spare Parts List.

When ordering spare parts, please use the Spare Parts List!

Parts list

LKHI-10, -15, -20, -25, -35, -40, -45, -50, -60

18

Pos.	Qty.	Denomination
1	1	Motor
2	1	Shroud
2a	1	Edge list (Included in pos. 2)
3	4	Screw
5	4	Distance sleeve
6	4	Washer for adaptor
7	4	Nut for adaptor
8	1	Compression ring with thread
9	1	Shaft with int./ext. thread and pin <input type="checkbox"/>
	1	Shaft with int./ext. thread
10	1	Connex pin
11	1	Retaining ring
12	1	Compression ring without thread
13	6	Screw
13a	6	Washer
14	1	Screw for safety guard
15	1	Washer
16	1	Safety guard
17	1	Adaptor
18	4	Screw for adaptor
19	2	Nut
20	2	Washer
21	1	Seal housing for flushed seal <input type="checkbox"/>
22	2	Screw <input type="checkbox"/>
23	2	Tube <input type="checkbox"/>
24 ♦	1	Lip seal <input type="checkbox"/>
25 ♦	1	O-ring <input type="checkbox"/>
26 ♦	1	O-ring <input type="checkbox"/>
27	1	Sleeve <input type="checkbox"/>
28	6	Cap nut
29	6	Washer
30	1	Back plate
31 ♦	1	O-ring
32 ♦	1	Stationary seal ring
33	1	Space ring
34 ♦	1	Rotating seal ring
35 ♦	1	Quad ring
36 ♦	1	Support ring
37	1	Rotating seal housing (incl. guide ring and washer)
38 ♦	1	Quad ring
39	1	Impeller
40	1	Impeller for impeller screw
41	1	Impeller screw
42 ♦	1	O-ring
43 ♦	1	O-ring
44	6	Stud bolt
45	1	Pump casing
Legs		
46a	1	Support bar, right
46b	1	Support bar, left
47	4	Leg
48	4	Screw
49	4	Spring washer
50	4	Nut
51	4	Screw
52	4	Washer
53	4	Pivot screw
54	4	Nut (only used for 3kW)

♦ : Service kit - EPDM, NBR, FPM
(See Spare Parts list)

: Parts for flushed shaft seal only

This page shows an exploded drawing of LKHI.

The drawing includes all items of the pump.
They are identical with the items in the Spare Parts List.

Exploded drawing

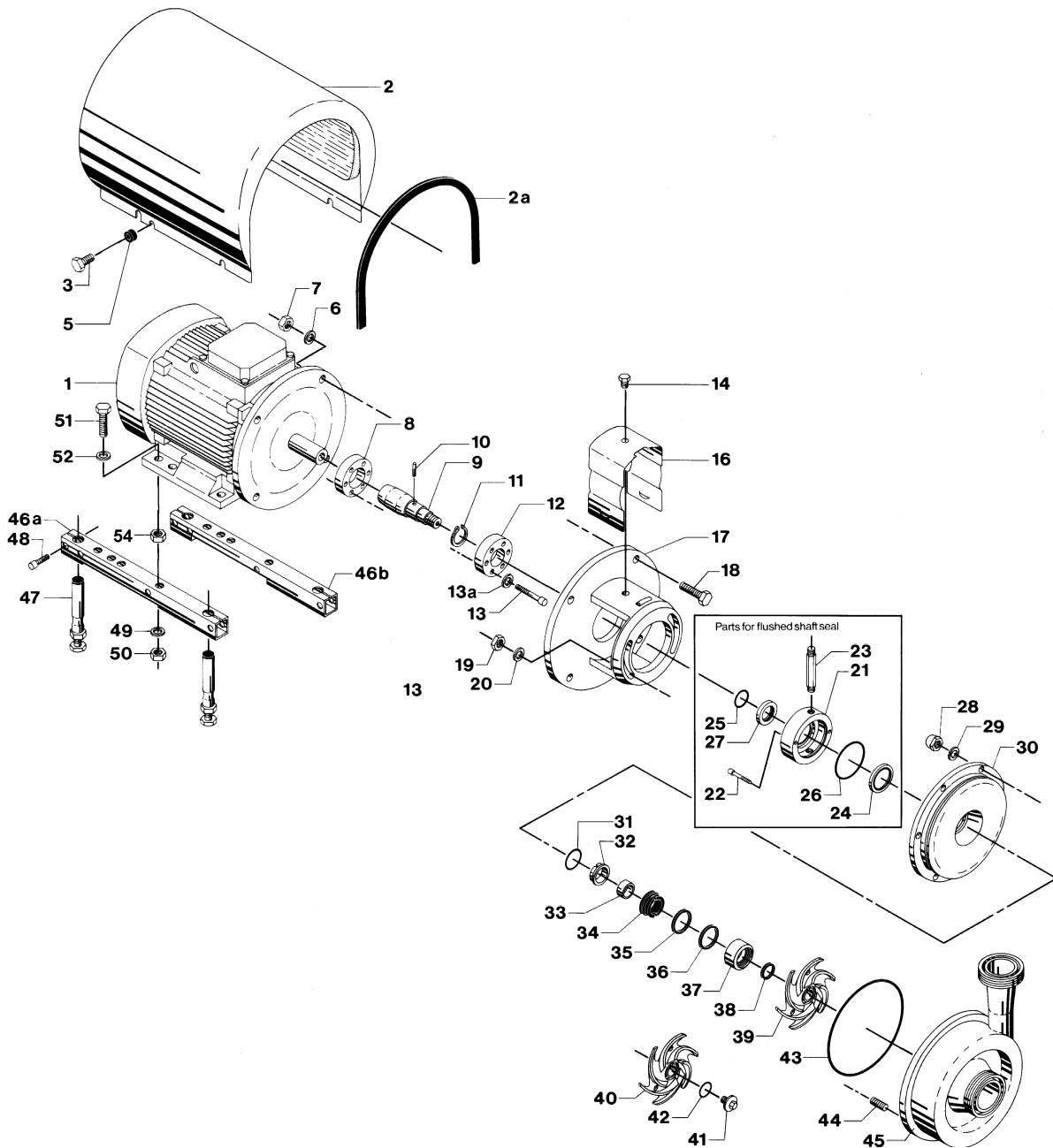

Drawing/Parts list

The drawing and the parts list include all items of the pump.

The items are identical with the items in the Spare Parts List.

When ordering spare parts, please use the Spare Parts List!

Parts list

LKHI-10, -15, -20, -25, -35, -40, -45, -50, -60

20

Pos.	Qty.	Denomination
1	1	Motor
2	1	Shroud
2a	1	Edge list (Included in pos. 2)
3	4	Screw
5	4	Distance sleeve
6	4	Washer for adaptor
7	4	Nut for adaptor
8	1	Compression ring with thread
9	1	Shaft with int./ext. thread and pin <input type="checkbox"/>
	1	Shaft with int./ext. thread
10	1	Connex pin
11	1	Retaining ring
12	1	Compression ring without thread
13	6	Screw
13a	6	Washer
14	1	Screw for safety guard
15	1	Washer
16	1	Safety guard
17	1	Adaptor
18	4	Screw for adaptor
19	2	Nut
20	2	Washer
21	1	Seal housing for flushed seal <input type="checkbox"/>
22	2	Screw <input type="checkbox"/>
23	2	Tube <input type="checkbox"/>
24 ♦	1	Lip seal <input type="checkbox"/>
25 ♦	1	O-ring <input type="checkbox"/>
26 ♦	1	O-ring <input type="checkbox"/>
27	1	Sleeve <input type="checkbox"/>
28	6	Cap nut
29	6	Washer
30	1	Back plate
31 ♦	1	O-ring <input type="checkbox"/>
32 ♦	1	Stationary seal ring
33	1	Space ring
34 ♦	1	Rotating seal ring
35 ♦	1	Quad ring
36 ♦	1	Support ring
37	1	Rotating seal housing (incl. guide ring and washer)
38 ♦	1	Quad ring
39	1	Impeller
40	1	Impeller for impeller screw
41	1	Impeller screw
42 ♦	1	O-ring <input type="checkbox"/>
43 ♦	1	O-ring <input type="checkbox"/>
44	6	Stud bolt
45	1	Pump casing
Legs		
46a	1	Support bar, right
46b	1	Support bar, left
47	4	Leg
48	4	Screw
49	4	Spring washer
50	4	Nut
51	4	Screw
52	4	Washer
53	4	Pivot screw
54	4	Nut (only used for 3kW)

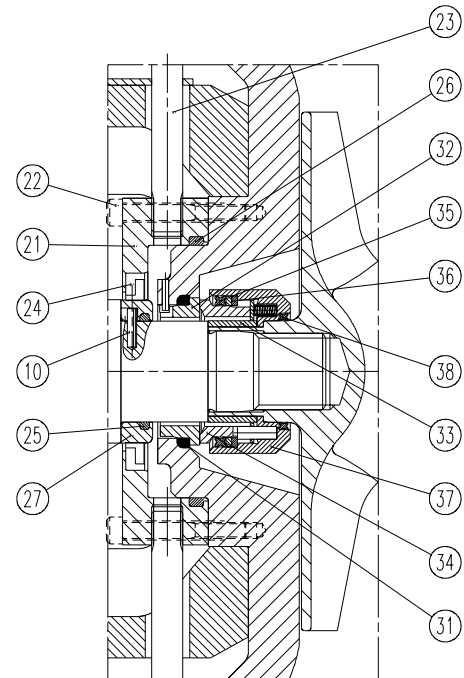

♦ : Service kit - EPDM, NBR, FPM
(See Spare Parts list)

: Parts for flushed shaft seal only

The drawing shows LKHI.

The items refer to the parts list on the opposite part of the page.

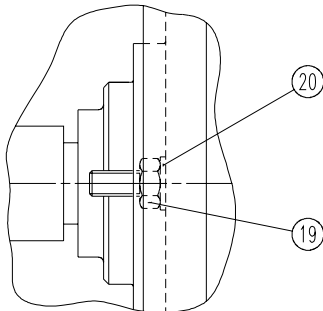
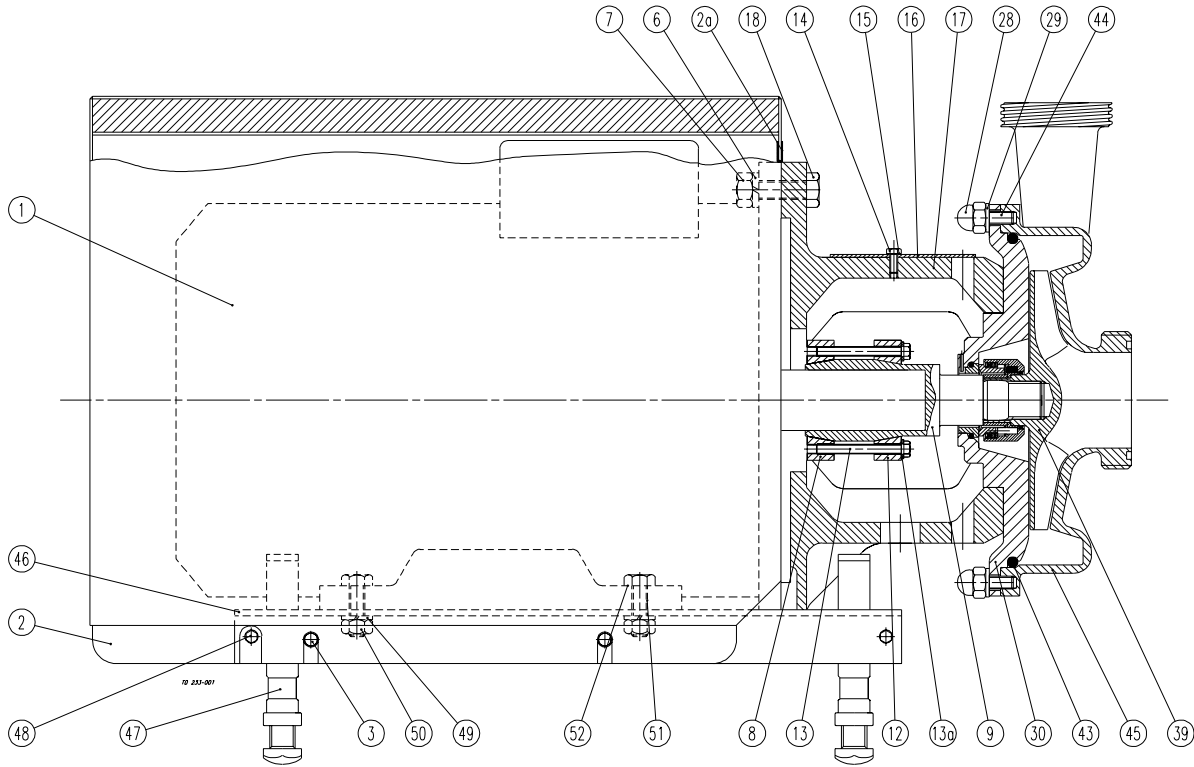

Mounting of back plate to adaptor

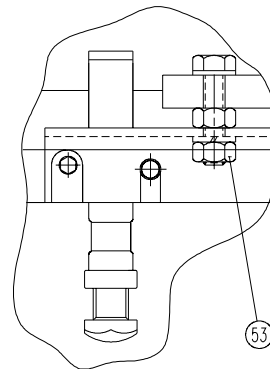

Only used for 3 kW

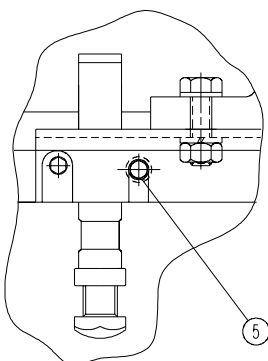

Only used for 5.5 / 7.5 / 18.5 kW

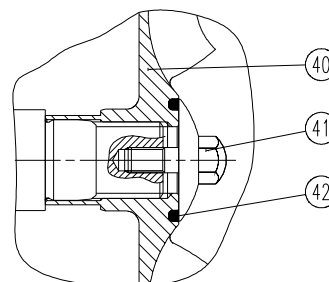

How to contact Alfa Laval

Contact details for all countries are continually updated on our website. Please visit www.alfalaval.com to access the information direct.