

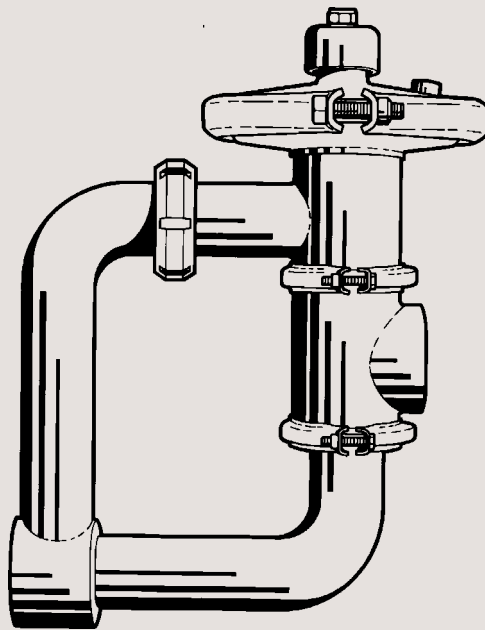

Instruction Manual

CPM-I-D60 Constant-Pressure Modulating Inlet Valve



Declaration of Conformity

The designating company

Alfa Laval

Company Name

6000 Kolding

Address

+45 79 32 22 00

Phone No.

hereby declare that

**CONSTANT-PRESSURE
MODULATING INLET VALVE**

Denomination

CPM-I-D60

Type

Year

Was manufactured in conformity with the provisions in the COUNCIL DIRECTIVE on mutual approximation of the laws of the Member States on the safety of machines (98/37/EC) with special reference to Annex 1 of the directive on essential safety and health requirements in relation to the construction and manufacture of machines.

Bjarne Søndergaard

Name

Vice President, R & D

Title

Alfa Laval

Company

B. Søndergaard

Signature

Designation



Table of contents

This manual is divided into main sections. - See below.

Safety

1. Important information 2
2. Warning signs 2
3. Safety precautions 3

Installation

1. Unpacking/Delivery 4
2. General installation 5
3. Welding 6
4. Fitting of Booster (optional extra) 7

Operation

1. Operation 8
2. Fault finding 9
3. Recommended cleaning 10

Maintenance

1. General maintenance 11
2. Dismantling 12
3. Assembly 14

Technical data

1. Technical data 16
2. Selection / Pressure drop - capacity diagrams 17

Drawings/Parts list

1. Parts list
 - CPM-I-D60 18+20
 - Booster (optional extra) 22+24
2. Exploded drawing
 - CPM-I-D60 19
 - Booster (optional extra) 23
3. Drawing
 - CPM-I-D60 21
 - Booster (optional extra) 25

Safety

Unsafe practices and other important information are emphasized in this manual.

Warnings are emphasized by means of special signs.

1. Important information

Always read the manual before using the valve!

2

- WARNING!** : Indicates that special procedures **must** be followed to avoid severe personal injury.
- CAUTION!** : Indicates that special procedures **must** be followed to avoid damage to the valve.
- NOTE!** : Indicates important information to simplify practices or to make them clearer.

2. Warning signs



: General warning.



: Caustic agents.

All warnings in the manual are summarized on this page.

Pay special attention to the instructions below so that severe personal injury and/or damage to the valve are avoided.

3. Safety precautions

Installation:



- : - **Always** read the technical data thoroughly (see page 16).
- **Always** release compressed air after use.
- **Never** touch the valve top if compressed air is supplied to the valve.
- **Never** dismantle the valve with valve and pipelines under pressure.

Operation:



- : - **Always** read the technical data thoroughly (see page 16).
- **Always** release compressed air after use.



- : **Never** touch the valve or the pipelines when processing hot liquids or when sterilizing.



- : **Never** touch the valve top if compressed air is supplied to the valve.



- : **Always** handle lye and acid with great care.

Maintenance:



- : - **Always** read the technical data thoroughly (see page 16).
- **Always** disconnect compressed air before service.



- : - **Never** service the valve when it is hot.
- **Never** service the valve and pipelines under pressure.

Installation

The instruction manual is part of the delivery.

Study the instructions carefully.

1. Unpacking/Delivery

1

CAUTION!

We cannot be held responsible for incorrect unpacking.

2

Check the delivery for:

1. Complete valve.
2. Delivery note.
3. Instruction manual.

3

Remove packing materials!

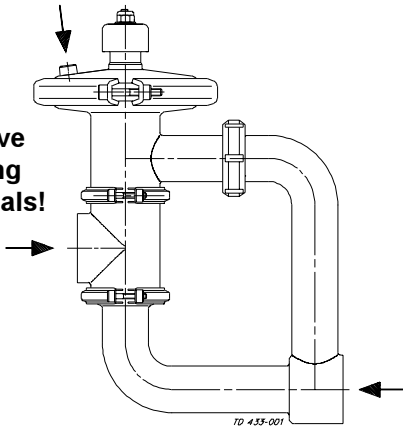

Clean the valve ports for possible packing materials.

4

Inspection!

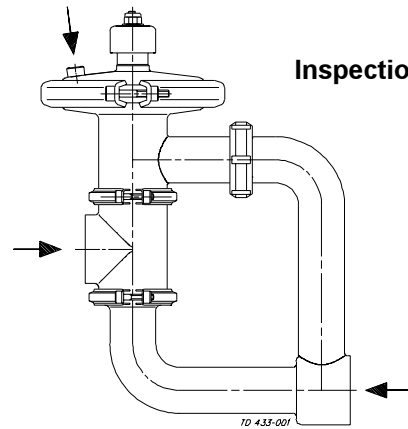

Inspect the valve for visible transport damages.

5

Caution!

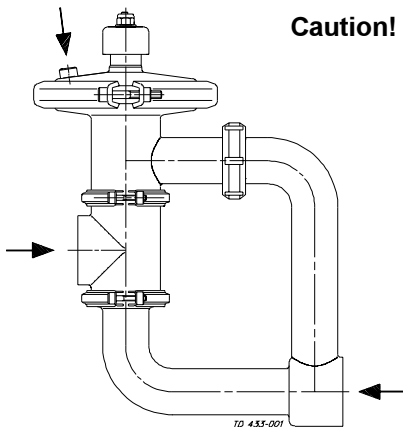

Avoid damaging the air connection and the valve ports.

Study the instructions carefully and pay special attention to the warnings!
The valve has welding ends as standard but can also be supplied with fittings.

2. General installation

1



- **Always** read the technical data thoroughly (see page 16).
- **Always** release compressed air after use.
- **Never** touch the valve top if compressed air is supplied to the valve.

CAUTION!

We cannot be held responsible for incorrect installation.

3

Risk of damage!

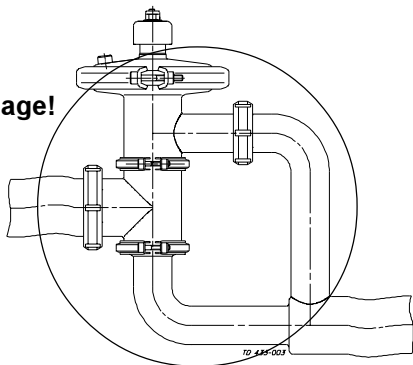

Avoid stressing the valve.

Pay special attention to:

- Vibrations.
- Thermal expansion of the tubes.
- Excessive welding.
- Overloading of the pipelines.

5

R1/4 " (BSP)

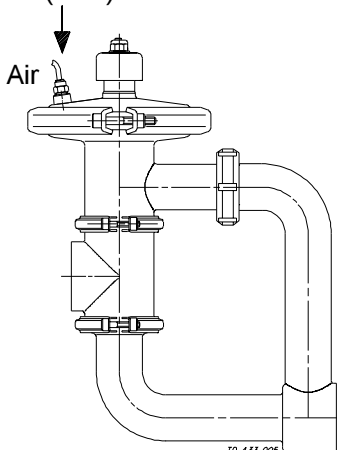

Air connection:

2

The required product pressure is preset by means of an air pressure regulating valve (optional extra).

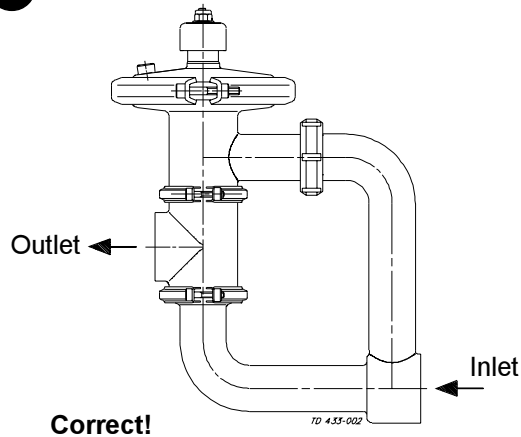

Correct!

Ensure that the flow direction is correct.

4

Remember seal rings!

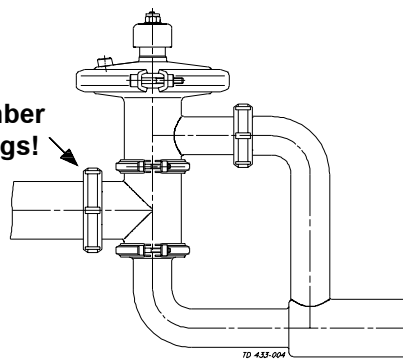

Fittings:

Ensure that the connections are tight.

6

Pressure regulating valve

As close as possible!

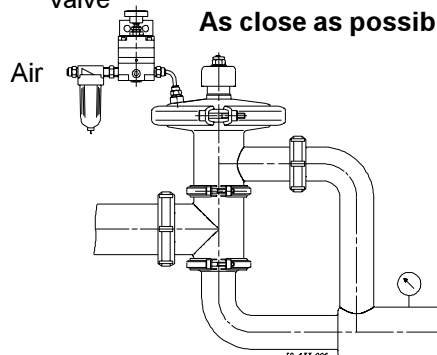

Air pressure regulating valve: (Optional extra)
It is recommended to install the air pressure regulating valve as close as possible to the valve.

Installation

Study the instructions carefully
The valve has welding ends as standard.
Weld carefully.

3. Welding

1

NOTE!

Never weld both the inlet and the outlet connections. If so, it will be impossible to service the lower valve body seal ring (16).

3

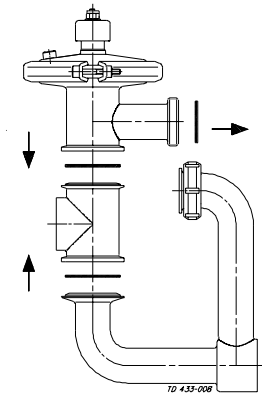

Welding the outlet connection:

Dismantle the valve in accordance with the instructions 1-2 on page 12.

5

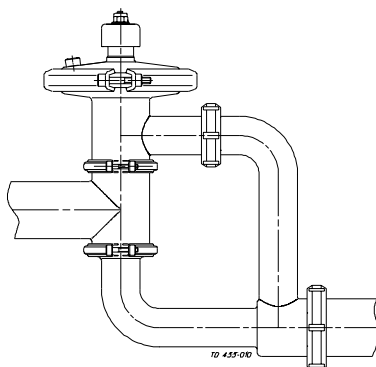

Welding the outlet connection:

Assemble the valve in accordance with the instructions 10-11 on page 15.

2

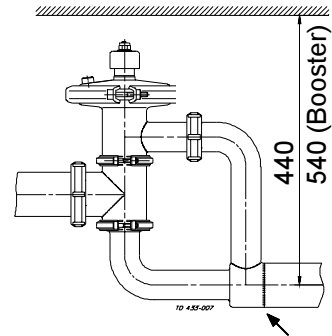

Caution!

Welding the inlet connection:

1. Weld the valve into the pipelines.
2. Maintain the minimum clearance so that the internal valve parts can be removed.

4

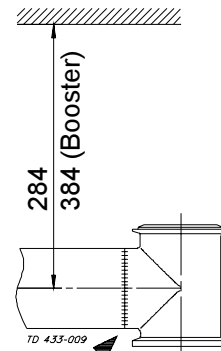

Caution!

Welding the outlet connection:

1. Weld lower valve body (10) into the pipelines.
2. Maintain the minimum clearance so that the internal valve parts can be removed.

6

Lift and lower
by hand!

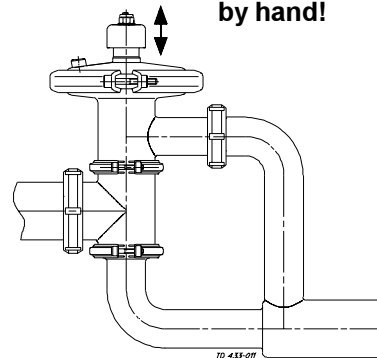

Pre-use check:

Lift and lower the valve top several times to ensure that the valve operates smoothly.

Pay special attention to the warning!

Study the instructions carefully and pay special attention to the warnings!
The items refer to the drawings and the parts list on the pages 22-25.

The valve can be supplied with a Booster to increase the permitted product pressure.

4. Fitting of Booster (optional extra)

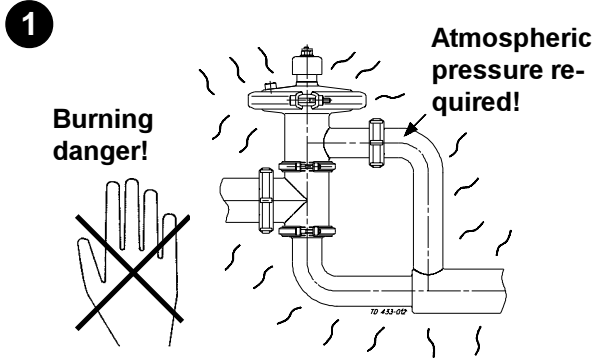

- ⚠ - **Never** touch the valve or the pipelines when processing hot liquids or when sterilizing.
- **Never** service the valve and pipelines under pressure.

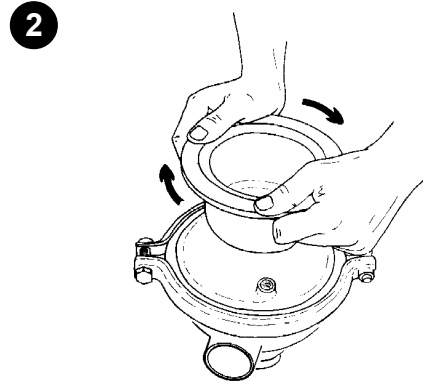

1. Remove the valve top in accordance with instruction 5 on page 12.
- Pay special attention to the warnings!**
2. Fit Booster housing (1) on the cover.
3. Fit and tighten lock nut (2).

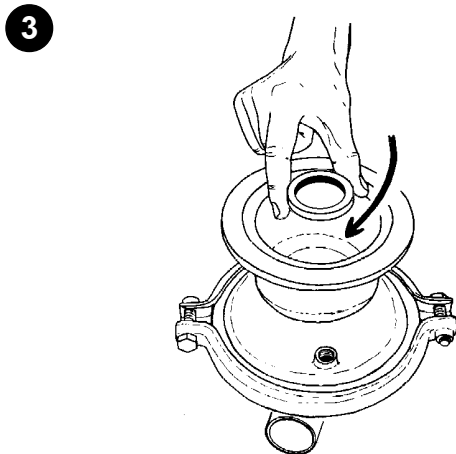

1. Fit washer (3).
2. Refit the washer and the top nut on the valve plug.

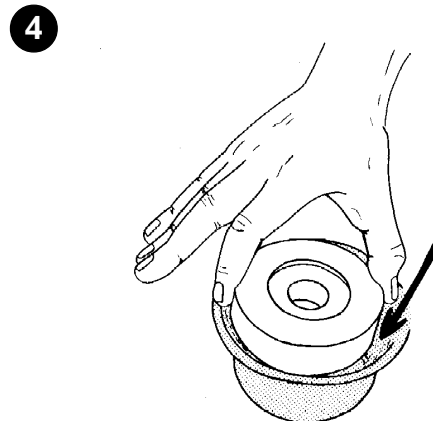

1. Turn diaphragm (7) inside out.
2. Place piston (6) in the diaphragm so that the hole is visible.

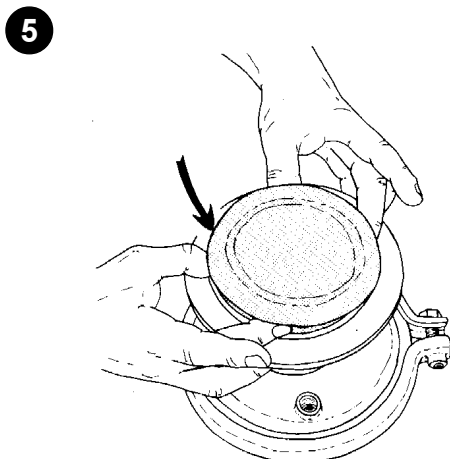

1. Roll diaphragm (7) down half it's lenght.
2. Fit the diaphragm with piston (6) in Booster housing (1).

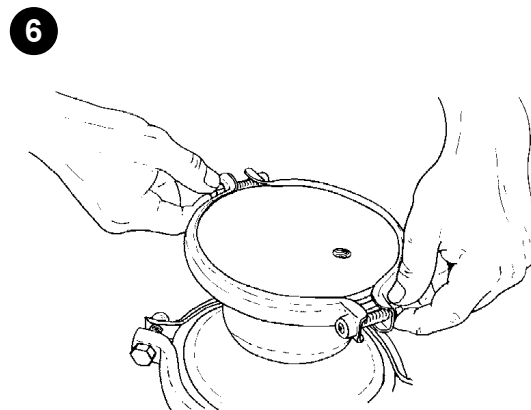

1. Fit cover (8) on Booster housing (1).
2. Fit and tighten clamp (9).
3. The valve and the Booster are now ready for operation.

Operation

8

The valve is lubricated, adjusted and tested before delivery.
Study the instructions carefully and pay special attention to the warnings!

The items refer to the drawings and the parts list on the pages 18-21.

1. Operation

1



- **Always** read the technical data thoroughly (see page 16).
- **Always** release compressed air after use.

CAUTION!

We cannot be held responsible for incorrect installation.

2

Burning danger!

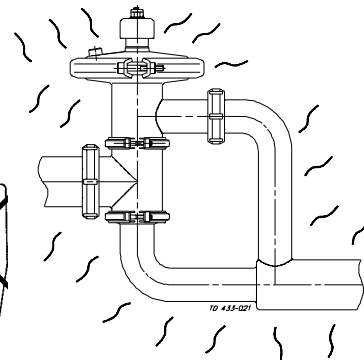

- **Never** touch the valve or the pipelines when processing hot liquids or when sterilizing.

3

Cutting danger!

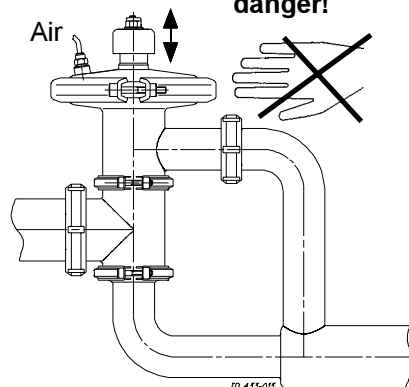

- **Never** touch the valve top if compressed air is supplied to the valve.

4

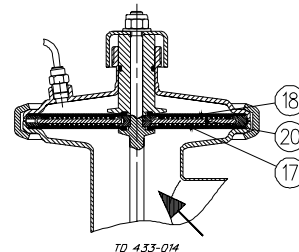

No vacuum!

CAUTION!

There must not be vacuum in the valve as air can be drawn into the product and diaphragm (17) can be pulled out from support sectors (20).

5

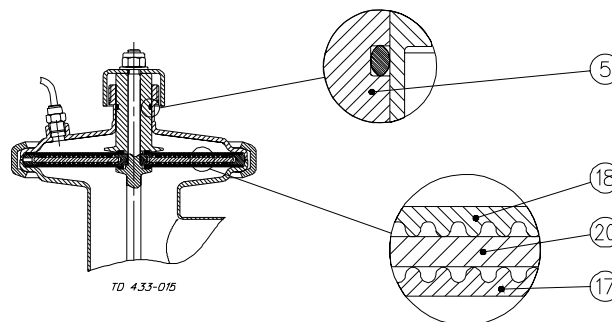

Lubricate if necessary!
(See page 11).

Lubrication:

1. Ensure smooth movement between diaphragms (17,18) and support sectors (20).
2. Ensure smooth movement of guide (5).

Study the instructions carefully.
Pay attention to possible faults.

The items refer to the drawings and the parts list on the pages 18-21.

2. Fault finding

NOTE!

Study the maintenance instructions carefully before replacing worn parts. - See page 11!

Problem	Cause/result	Repair
The valve does not maintain the preset pressure	<ul style="list-style-type: none"> - Faulty diaphragm - Guide (5) seizes - Incorrect operating range - The available air pressure is lower than the product pressure - The air pressure is not correctly adjusted - Faulty air pressure regulating valve or incorrect type 	<ul style="list-style-type: none"> - Replace the diaphragm - Lubricate the guide (see page 8) - Check the pressure drop over the valve and check the flow rate (see page 17) - Increase the air pressure eg. by using a Booster (see page 7) - Readjust the air pressure - Repair the valve or check that it is pressure compensating
Product leakage	<ul style="list-style-type: none"> - Worn diaphragm - Product affected diaphragm 	Replace the diaphragm
Air leakage	<ul style="list-style-type: none"> - Worn O-ring - Worn diaphragm - Worn and hard diaphragm 	<ul style="list-style-type: none"> - Replace the O-ring - Replace the diaphragm - Replace by a diaphragm of a different grade for higher temperature (see page 16)
Valve plug moving too fast up and down (unstable)	Pressure pulsations because of fast changes in process conditions	Use an air throttling valve (optional extra) between the air pressure regulating valve and the CPM-I-D60 valve.

Operation

10

The valve is designed for cleaning in place (CIP).
CIP = Cleaning In Place.

Study the instructions carefully and pay special attention to the warnings!

NaOH = Caustic Soda.

HNO₃ = Nitric acid.

3. Recommended cleaning

1

Caustic danger!



Always use rubber gloves!



Always use protective goggles!



Always handle lye and acid with great care.

2

Burning danger!

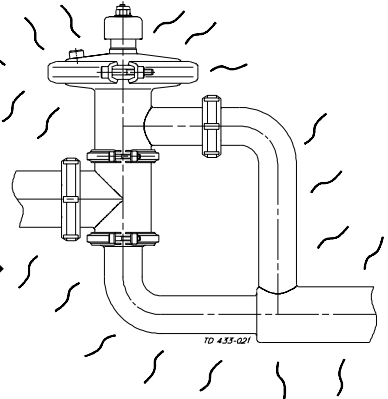
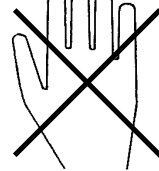

Never touch the valve or the pipelines when sterilizing.

3

No air pressure!

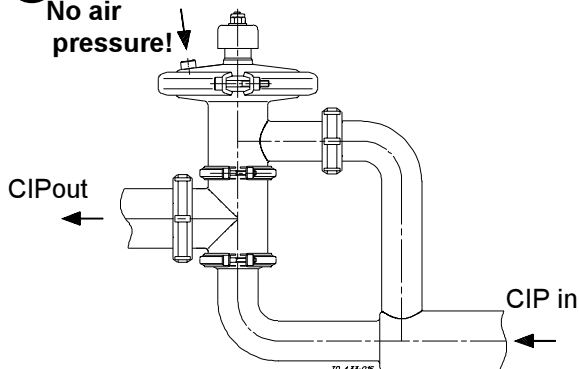

Ensure that the valve is fully open to allow for maximum CIP flow.

4

Examples of cleaning agents:

Use clean water, free from chlorides.

1. 1% by weight NaOH at 70°C.

1 kg NaOH	+	100 l water	= Cleaning agent.
-----------	---	-------------	-------------------

2.2 l 33% NaOH	+	100 l water	= Cleaning agent.
----------------	---	-------------	-------------------

2. 0.5% by weight HNO₃ at 70°C.

0.7 l 53% HNO ₃	+	100 l water	= Cleaning agent.
----------------------------	---	-------------	-------------------

5

1. Avoid excessive concentration of the cleaning agent

⇒ Dose gradually!

2. Adjust the cleaning flow to the process

⇒ Milk sterilization/viscous liquids

⇒ Increase the cleaning flow!

3. Always rinse well with clean water after the cleaning.

6

CAUTION!

The cleaning agents must be stored/disposed of accordance with current rules/directives.

Maintain the valve regularly.
Study the instructions carefully and pay special attention to the warnings!

Always keep spare diaphragms and O-rings in stock.

1. General maintenance

1

 - **Always** read the technical data thoroughly (see page 16).
- **Always** disconnect the compressed air before service.

Caution!
All scrap must be stored/disposed of accordance with current rules/directives.

2

Burning danger!

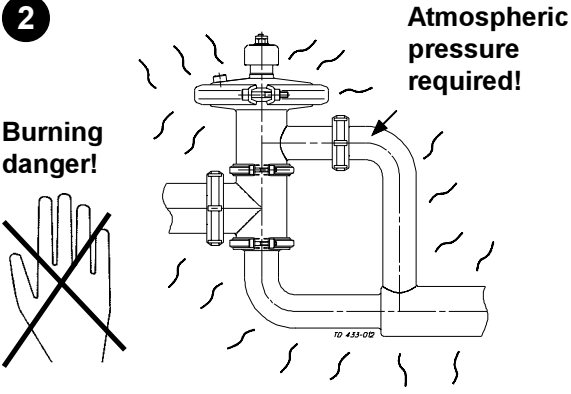

Atmospheric pressure required!

 - **Never** service the valve when it is hot.
- **Never** service the valve and pipelines under pressure.

Ordering spare parts

- Contact the Sales Department.
- Order from the Spare Parts List.

Recommended spare parts: Service kits (see Spare Parts List).

	Diaphragms	O-ring
Preventive maintenance	Replace after 12 months	Replace when replacing the diaphragms
Maintenance after leakage (leakage normally starts slowly)	Replace at the end of the day	Replace when replacing the diaphragms
Planned maintenance	<ul style="list-style-type: none"> - Regular inspection for leakage and smooth operation - Keep a record of the valve - Use the statistics for planning of inspections Replace after leakage	Replace when replacing the diaphragms

- Lubrication :** (Before assembly)
- Guide: Molycote longtherm 2 Plus.
 - Sectors: Molycote 111.
 - Threads: Molycote TP42.

Maintenance

12

Study the instructions carefully.
The items refer to the drawings and the parts list on the pages 18-21.

Handle scrap correctly.

2. Dismantling

1

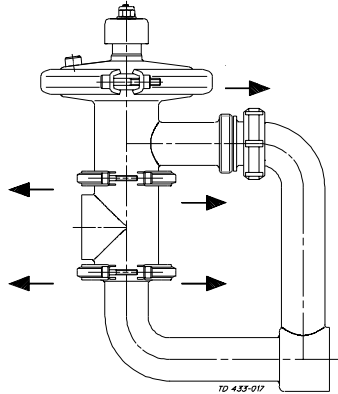

1. Remove clamps (14, 15).
2. Loosen the connection between valve body (12) and inlet tube (9).

2

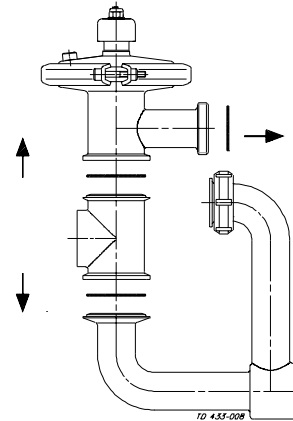

1. Remove inlet tube (9) and lower valve body (10).
2. Remove seal rings (8, 16).

3

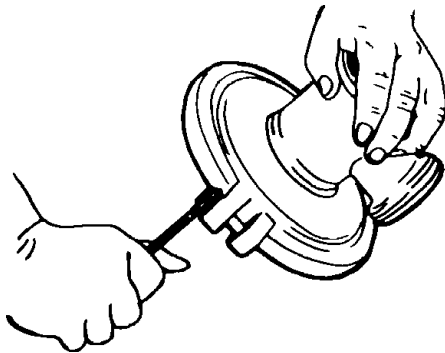

Remove clamp (22, 23)

4

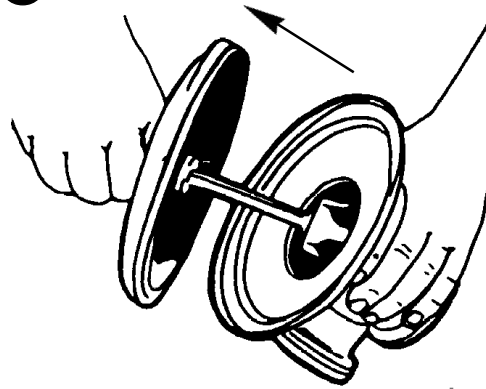

Remove cover (19) together with the internal parts of the valve.

5

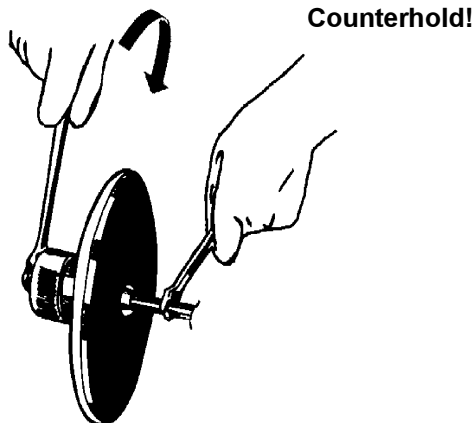

Remove top nut (1), washer (2) and top (3).

6

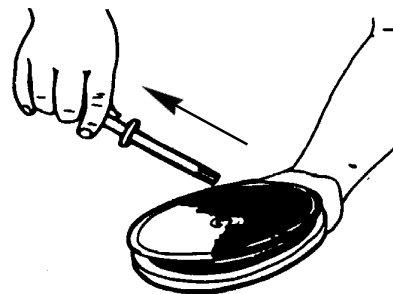

Remove plug (7) from the diaphragm unit and guide (5).

CAUTION!

Ensure that cover (19) is turned downwards and plug (7) is pulled upwards so that sectors (20) are not separated from diaphragms (17, 18).

Study the instructions carefully.
The items refer to the drawings and the parts list on
the pages 18-21.

Handle scrap correctly.

2. Dismantling

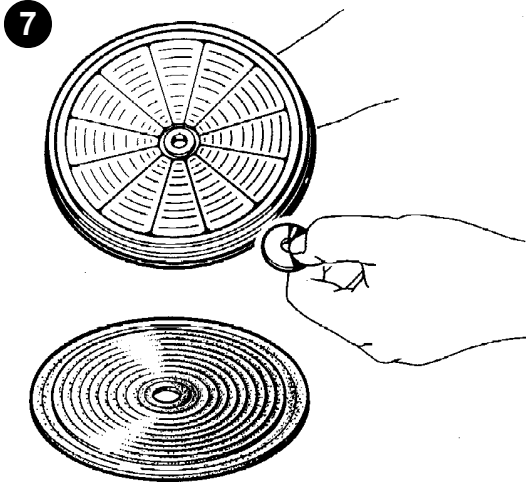

Remove lower inner ring (13) and lower diaphragm (17).

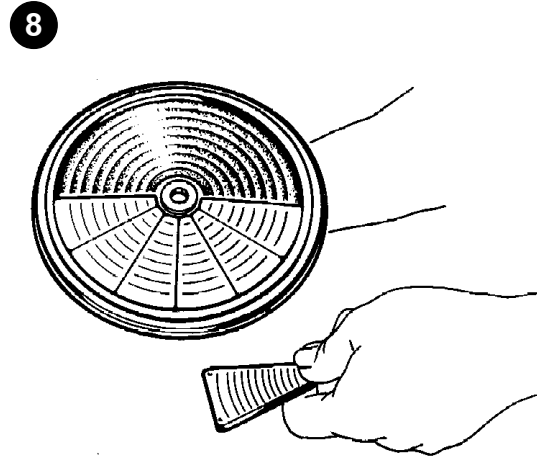

Remove sectors (20).

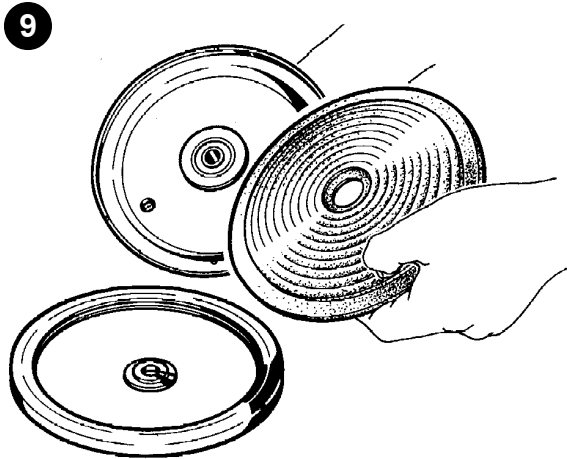

Remove outer ring (21), upper inner ring (13)
and upper diaphragm (18).

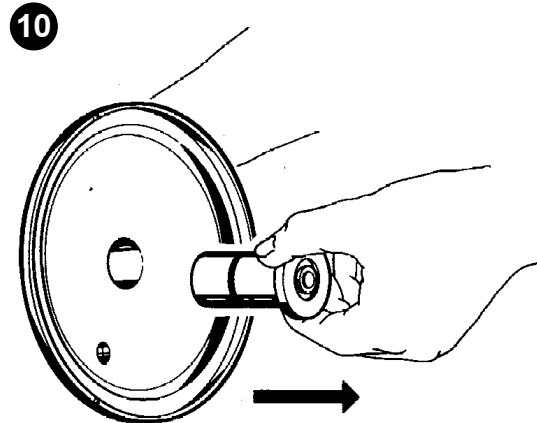

Remove guide (5).

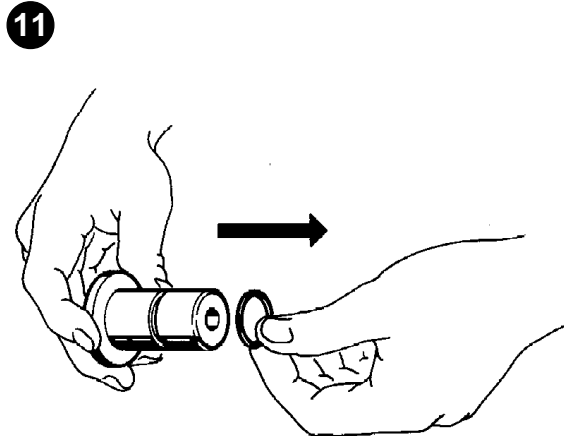

Remove O-ring (6).

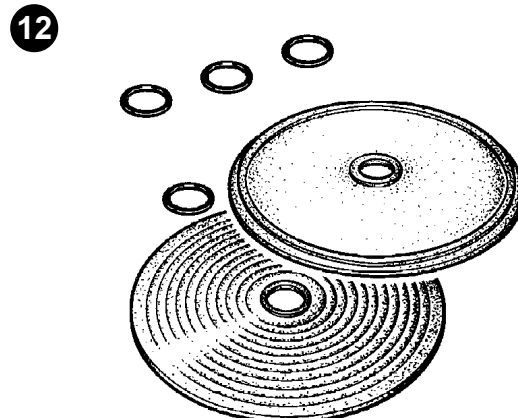

Replace the O-ring, the seal rings and the
diaphragms.

Maintenance

Study the instructions carefully.
The items refer to the drawings and the parts list on the pages 18-21.

Lubricate the guide, the sectors and the threads before assembly.

3. Assembly

1

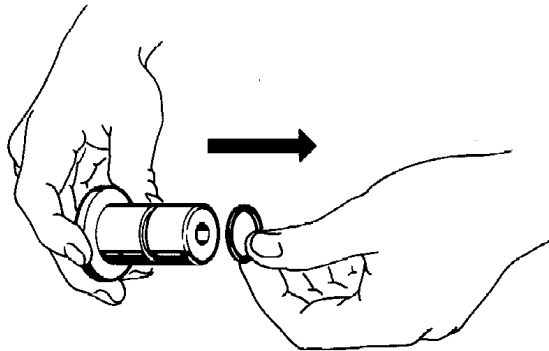

Fit O-ring (6)

2

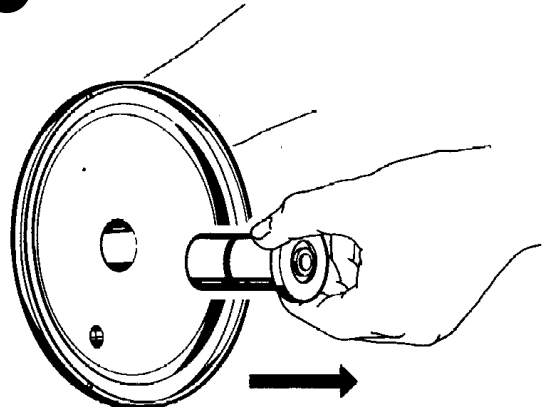

Lubricate guide (5), and fit it.

NOTE!

Turn cover (19) downwards before continuing.

3

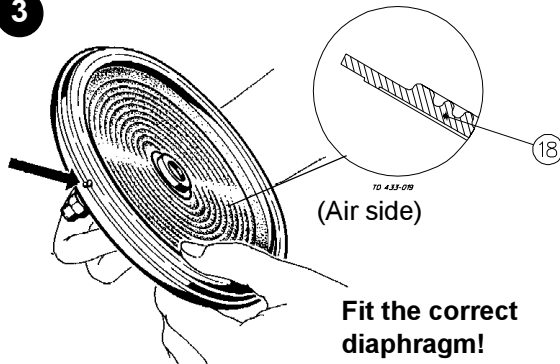

Fit the correct diaphragm!

Fit upper diaphragm (18), upper inner ring (13) and outer ring (21) on guide (5) and cover (19).

NOTE!

The outer ring must be turned so that the indication hole is fixed to the indication hole in the cover.

4

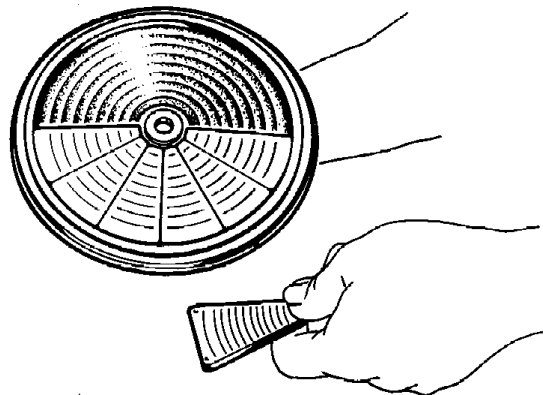

Fit sectors (20) between upper inner ring (13) and outer ring (21).

5

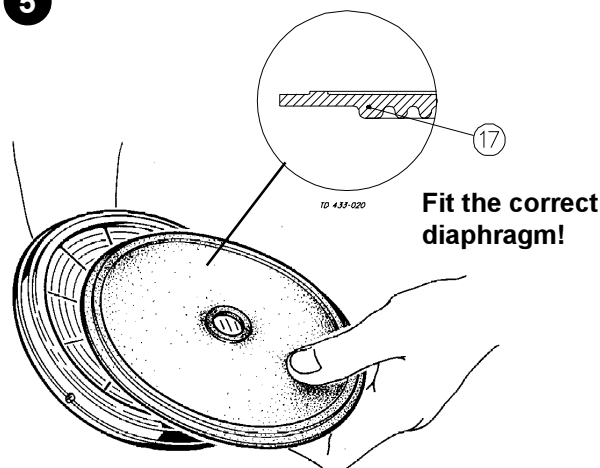

Fit the correct diaphragm!

Fit lower inner ring (13) and lower diaphragm (17).

6



Fit plug (7) in the diaphragm unit and guide (5) until the flange of the plug contacts lower diaphragm (17).

Study the instructions carefully.
The items refer to the drawings and the parts list on the pages 18-21.

Lubricate the guide, the sectors and the threads before assembly.

3. Assembly

7

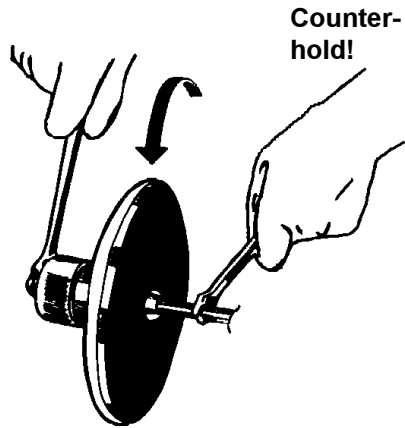

Fit top (3), washer (2) and top nut (1).

8

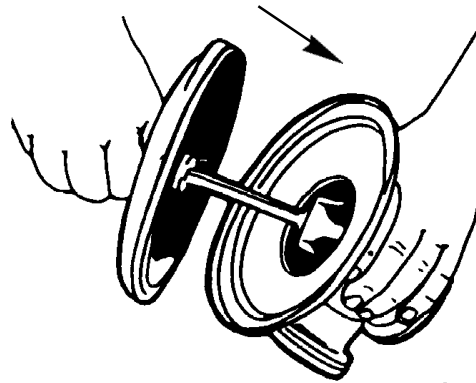

Fit cover (19) together with the internal parts of the valve.

9

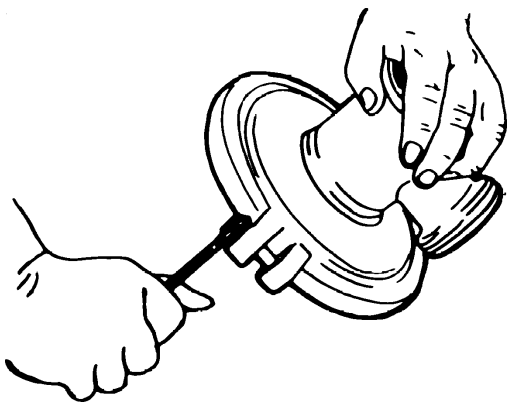

Fit and tighten clamp (22, 23).

10

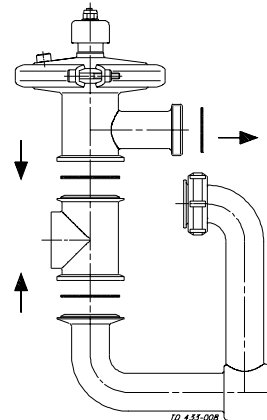

1. Fit seal rings (8, 16).
2. Fit lower valve body (10) and inlet tube (9).

11

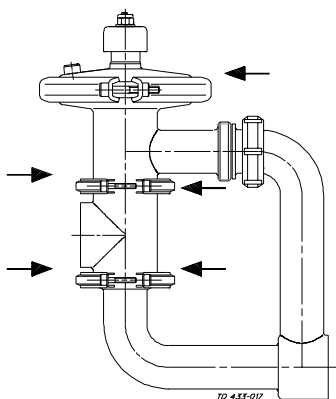

1. Tighten the connection between valve body (12) and inlet tube (9).
2. Fit and tighten clamps (14, 15).

12

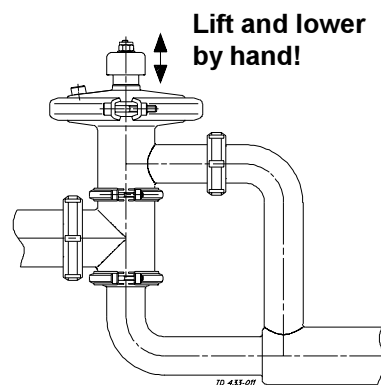

Pre-use check:

Lift and lower the valve top a few times to ensure that the valve operates smoothly.

Pay special attention to the warning!

Technical data

It is important to observe the technical data during installation, operation and maintenance.

Inform the personnel about the technical data.

16

1. Technical Data

Data

Max. product pressure	1000 kPa (10 bar)
Min. product pressure	0 kPa (0 bar = Atmospheric)
Temperature range	-10°C to +95°C
Temperature range (with upper diaphragm in PTFE/EPDM)	-10°C to +140°C
Air pressure	0 to 600 kPa (0 to 6 bar)
Flow range Kv, fully open ($\Delta p = 1\text{bar}$)	Approx. 60m ³ /h

Materials

Product wetted steel parts	AISI 316L
Other steel parts	AISI 304
Upper diaphragm	Nitrile (NBR), (standard)
Lower diaphragm	PTFE covered EPDM rubber, (standard)
Alternative upper diaphragm	EPDM/PTFE (for temperatures 95-140° C)
O-ring	Nitrile (NBR), (standard)
Alternative O-ring	Fluorinated rubber (FPM) (for temperatures above 95° C)
Finish	Semi bright

It is important to observe the technical data during installation, operation and maintenance.

Inform the personnel about the technical data.

2. Selection / Pressure drop - capacity diagram

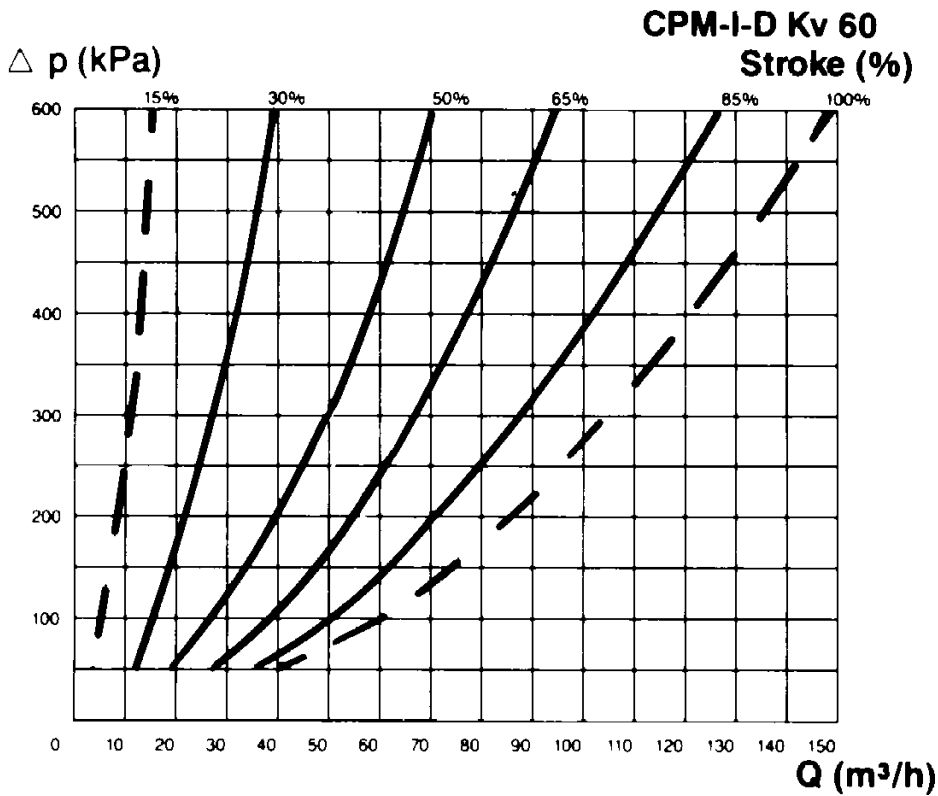

NOTE! For the diagrams the following applies:
 Medium: Water (20°C).
 Measurement: In accordance with VDI 2173.

Example of using the diagram:

1. Pressure drop $\Delta p = 300$ kPa.
 2. Flow = 50 m³/h.
- The intersection is on the 50% curve.

Drawing/Parts list

The drawing and the parts list include all items.

The items are identical with the items in the Spare Parts List.
When ordering spare parts, please use the Spare Parts List!

Parts list CPM-I-D60

18

Item	Qty.	Denomination
1	1	Nut
2	1	Washer
3	1	Top
5	1	Guide
6 Δ	1	O-ring
7	1	Plug
8 Δ	1	Seal ring
9	1	Inlet tube
10	1	Valve body, lower
12	1	Valve body
13	2	Inner ring
14	4	Clamp half
15	4	Screw
16Δ	2	Valve body seal ring
17Δ	1	Diaphragm
18Δ	1	Diaphragm
19	1	Cover
20	12	Support sector
21	1	Outer ring
24	1	Clamp set

Δ : Service kit
(See Spare Parts List)

This page shows an exploded drawing of CPM-I-D60.

The drawing includes all items of the valve. They are identical with the items in the Spare Parts List.

Exploded drawing

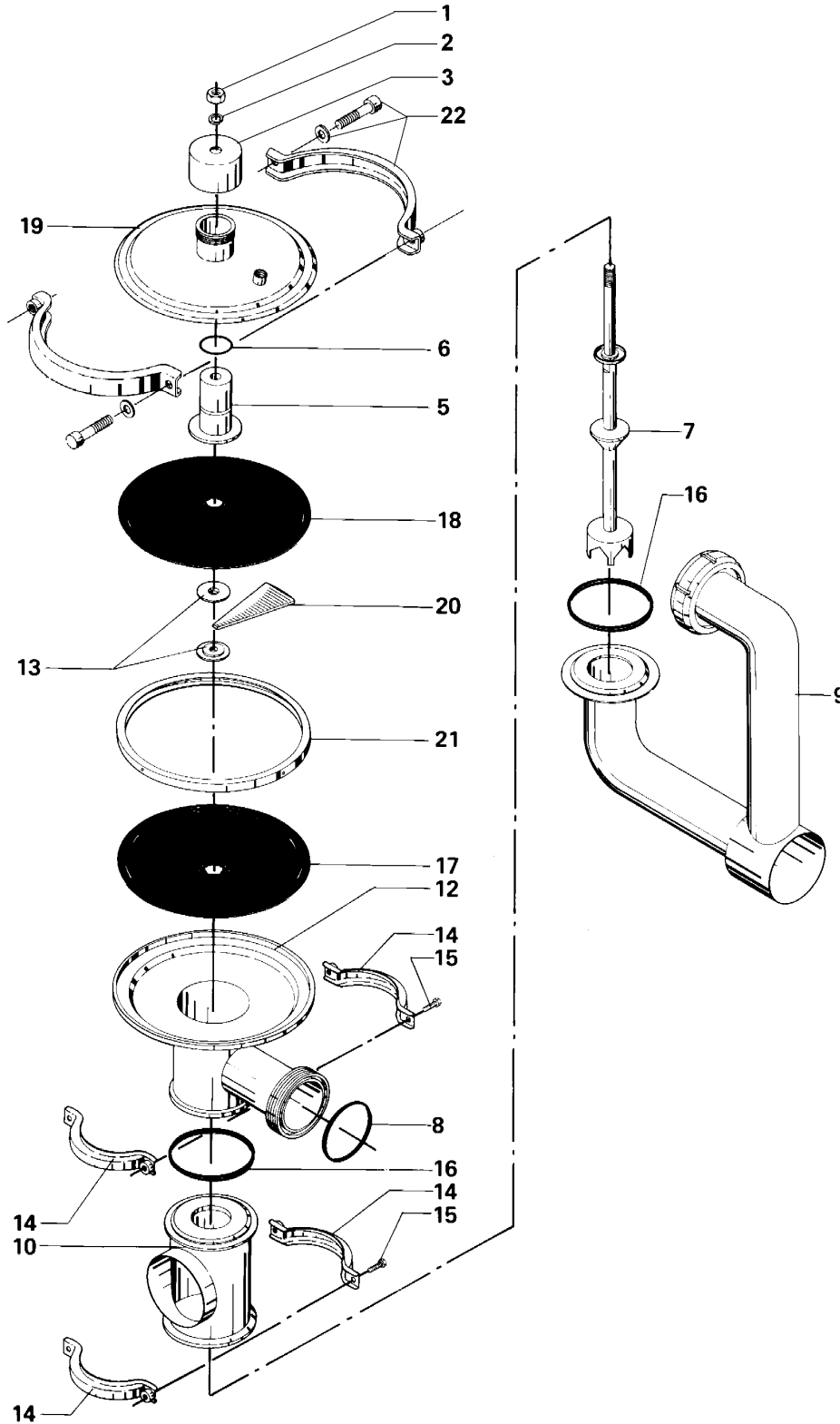

Drawing/Parts list

The drawing and the parts list include all items.

The items are identical with the items in the Spare Parts List.

When ordering spare parts, please use the Spare Parts List!

Parts list CPM-I-D60

20

Item	Qty.	Denomination
1	1	Nut
2	1	Washer
3	1	Top
5	1	Guide
6 Δ	1	O-ring
7	1	Plug
8 Δ	1	Seal ring
9	1	Inlet tube
10	1	Valve body, lower
12	1	Valve body
13	2	Inner ring
14	4	Clamp half
15	4	Screw
16Δ	2	Valve body seal ring
17Δ	1	Diaphragm
18Δ	1	Diaphragm
19	1	Cover
20	12	Support sector
21	1	Outer ring
24	1	Clamp set

Δ : Service kit
(See Spare Parts List)

The drawing below shows CPM-I-D60.

The items refer to the parts list on the opposite part of the page.

Drawing

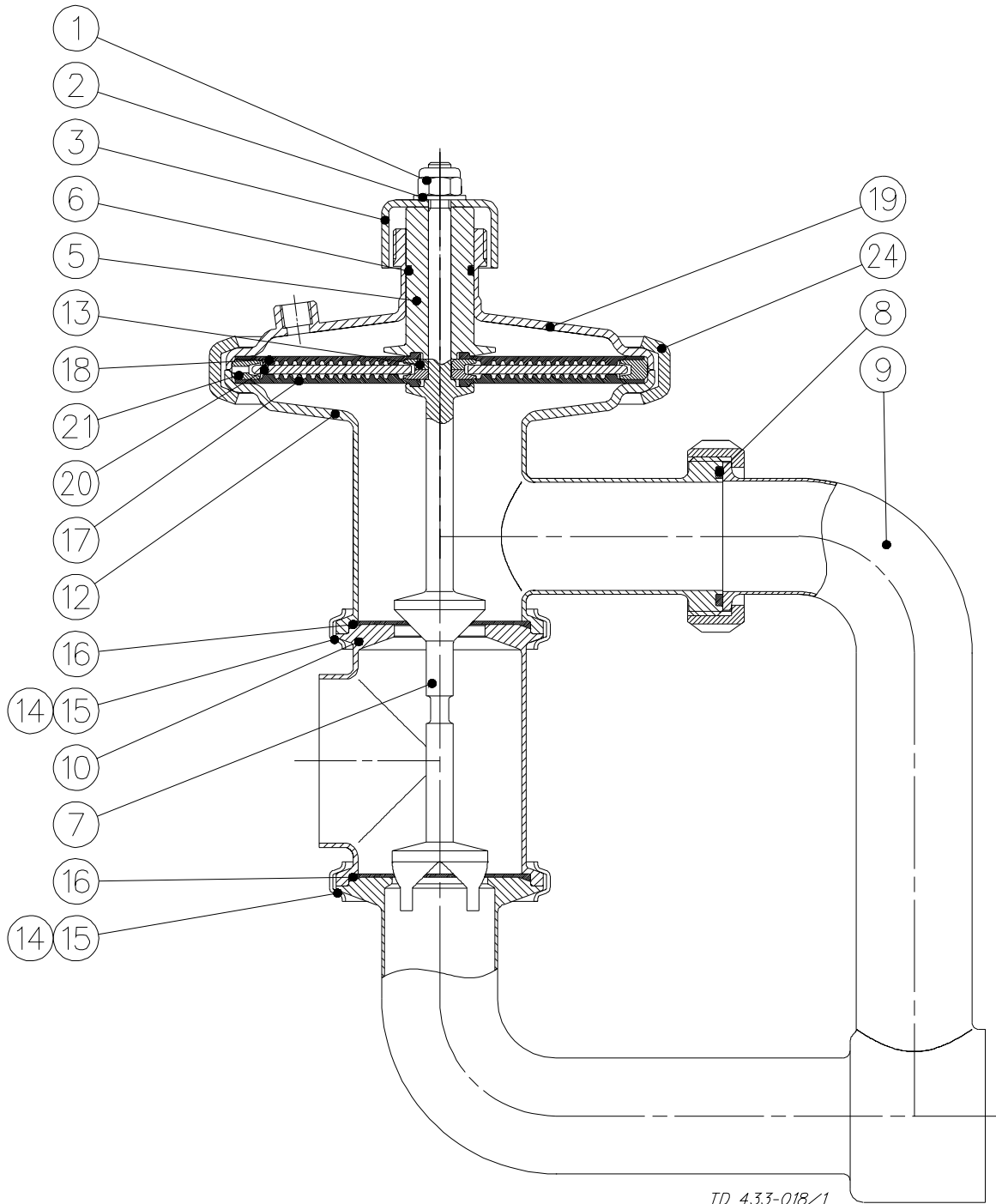

TD 433-018/1

Drawing/Parts list

The drawing and the parts list include all items.

The items are identical with the items in the Spare Parts List.

When ordering spare parts, please use the Spare Parts List!

Parts list Booster

22

Item	Qty.	Denomination
1	1	Booster housing
2	1	Lock nut
3	1	Washer
4	1	Spring washer
5	1	Nut
6	1	Booster piston
7 Δ	1	Diaphragm
8	1	Booster cover
9	1	Clamps and screws

Δ : Service kit
(See Spare Parts List)

This page shows an exploded drawing of the Booster.

The drawing includes all items of the valve.
They are identical with the items in the Spare Parts List.

Exploded drawing

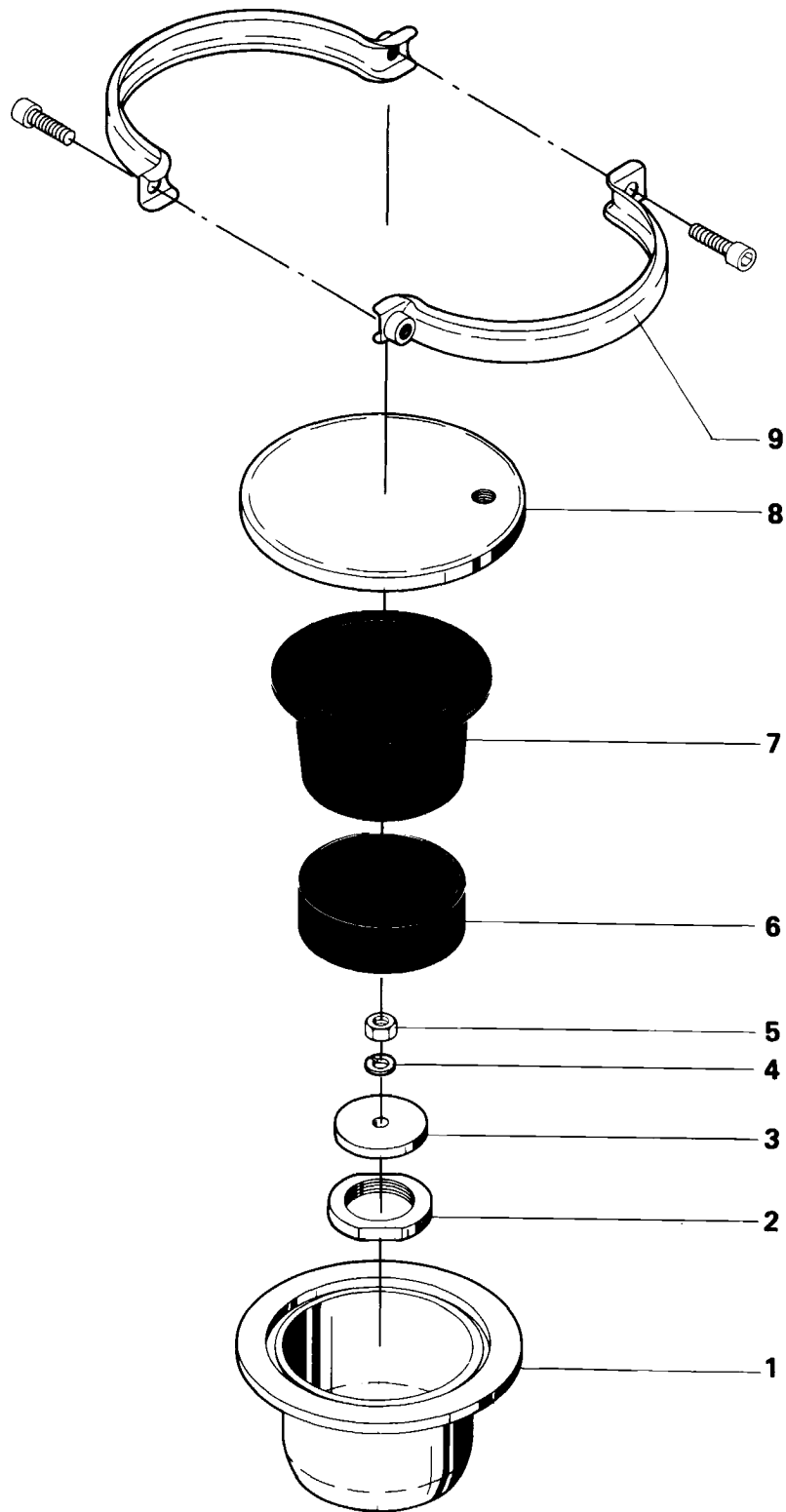

Drawing/Parts list

The drawing and the parts list include all items.

The items are identical with the items in the Spare Parts List.

When ordering spare parts, please use the Spare Parts List!

Parts list Booster

24

Item	Qty.	Denomination
1	1	Booster housing
2	1	Lock nut
3	1	Washer
4	1	Spring washer
5	1	Nut
6	1	Booster piston
7 Δ	1	Diaphragm
8	1	Booster cover
9	1	Clamps and screws

Δ : Service kit
(See Spare Parts List)

The drawing below shows the Booster.

The items refer to the parts list on the opposite part of the page.

Drawing

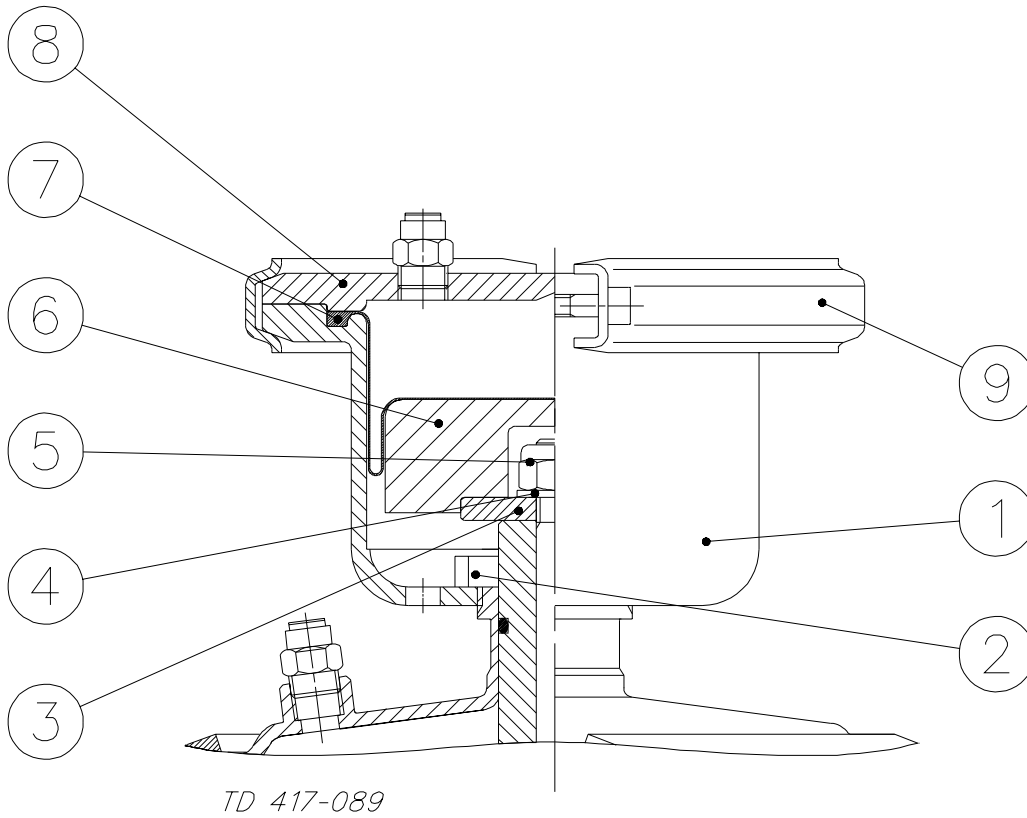

How to contact Alfa Laval

Contact details for all countries are continually updated on our website. Please visit www.alfalaval.com to access the information direct.