

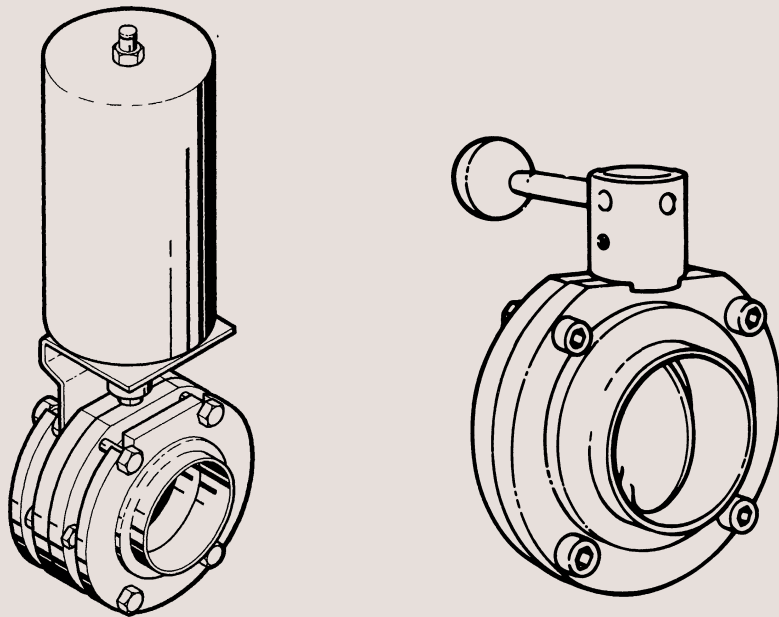

# Instruction Manual

## LKB Automatic or Manual Butterfly Valve



# Declaration of Conformity

## The designating company

**Alfa Laval**

Company Name

**6000 Kolding**

Address

**+45 79 32 22 00**

Phone No.

hereby declare that

**Automatic or Manual Butterfly Valve**

Denomination

**LKB**

Type

Year

Was manufactured in conformity with the provisions in the COUNCIL DIRECTIVE of 14 June 1989 on mutual approximation of the laws of the Member States on the safety of machines (89/392/EEC as amended by directives 91/368/EEC and 93/44/EEC) with special reference to Annex 1 of the directive on essential safety and health requirements in relation to the construction and manufacture of machines.

**Bjarne Søndergaard**

Name

**Vice President, R & D**

Title

**Alfa Laval**

Company



Signature

**Designation**



# Table of contents

*This manual is divided into main sections. - See below.*

## Safety

1. Important information .....	2
2. Warning signs .....	2
3. Safety precautions .....	3

## Installation

1. Unpacking/Delivery .....	4
2. General installation .....	5
3. Welding .....	6
4. Fitting actuator/bracket/handle .....	7
5. Indication and control equipment .....	8

## Operation

1. Operation .....	9
2. Fault finding .....	10
3. Recommended cleaning .....	11

## Maintenance

1. General maintenance .....	12
2. Dismantling of valve - LKB/LKB-2 .....	14
3. Assembly of valve - LKB/LKB-2 .....	15
4. Dismantling of valve - LKB-F .....	16
5. Assembly of valve - LKB-F .....	17
6. Dismantling of actuator .....	18
7. Assembly of actuator .....	19

## Technical data

1. Technical data .....	20
-------------------------	----

## Drawings/Parts list

1. Parts list	
- LKB/LKB-2/LKB-F .....	22+24
- Handles .....	26+28
- LKLA/LKLA-T, ø85mm .....	30+32
- LKLA/LKLA-T, ø133mm .....	34+36
2. Exploded drawing	
- LKB/LKB-2/LKB-F .....	23
- Handles .....	27
- LKLA/LKLA-T, ø85mm .....	31
- LKLA/LKLA-T, ø133mm .....	35
3. Drawing	
- LKB/LKB-2/LKB-F .....	25
- Handles .....	29
- LKLA/LKLA-T, ø85mm .....	33
- LKLA/LKLA-T, ø133mm .....	37

## Appendix

Spare Parts

# Safety

Unsafe practices and other important information are emphasized in this manual.

Warnings are emphasized by means of special signs.

## 1. Important information

Always read the manual before using the valve!

**WARNING!**

: Indicates that special procedures **must** be followed to avoid severe personal injury.

**CAUTION!**

: Indicates that special procedures **must** be followed to avoid damage to the valve.

**NOTE!**

: Indicates important information to simplify practices or to make them clearer.

---

## 2. Warning signs



: General warning.



: Caustic agents.

All warnings in the manual are summarized on this page.

"Mushrooms" = Fastening connections on the end cap.

## 3. Safety precautions

### Installation:



- : - **Always** observe the technical data (see page 20).
- **Always** release compressed air after use.
- **Never** touch the coupling between the valve body and the actuator if compressed air is supplied to the actuator.

### Operation



- : **Always** observe the technical data (see page 20).
- : **Never** touch the valve or the pipelines when processing hot liquids or when sterilizing.
- : **Never** touch the coupling between the valve body and the actuator if compressed air is supplied to the actuator.
- : **Always** handle lye and acid with great care.

### Maintenance:



- : - **Always** observe the technical data (see page 20)
- **Always** release compressed air after use.
- : - The valve must **never** be hot when servicing it.
- The valve/actuator and the pipelines must **never** be pressurised when servicing the valve/actuator.
- : **Never** stick your fingers through the valve ports if the valve is supplied with compressed air.
- : **Never** touch the coupling between the valve body and the actuator if compressed air is supplied to the actuator.
- : The actuator springs are **not** caged (ø85 mm, NC/NO).
- : - **Never** use compressed air for removing the end cap of the actuator.
- **Always** fit the end cap with the "mushrooms" turned outwards and position it correctly before supplying compressed air to the actuator.

# Installation

The instruction manual is part of the delivery.  
Study the instructions carefully.  
The items refer to the drawings and parts list on the pages 22-25.

The valve is supplied as separate parts as standard (for welding).  
The valve is assembled before delivery, if it is supplied with fittings (LKB/LKB-2).

## 1. Unpacking/Delivery

**1**

### NOTE!

We cannot be held responsible for incorrect unpacking.

### Check the delivery:

1. Complete valve (see 2).
2. Complete actuator, if supplied (see 3).
3. Bracket for actuator, if supplied (see 3).
4. Complete handle, if supplied.
5. Delivery note.
6. Instruction manual.

**2**

### Separate parts for welding!

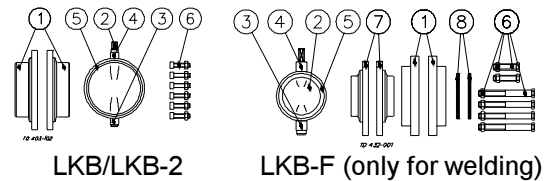

### Standard delivery of valve parts:

1. Two valve body halves (1).
2. Valve disc (2) fitted in seal ring (5).
3. Two bushes (3.4) fitted on the disc stem.
4. A set of screws and nuts (6).
5. Two Flanges (7) and two flange seal rings (8), (LKB-F).

**3**

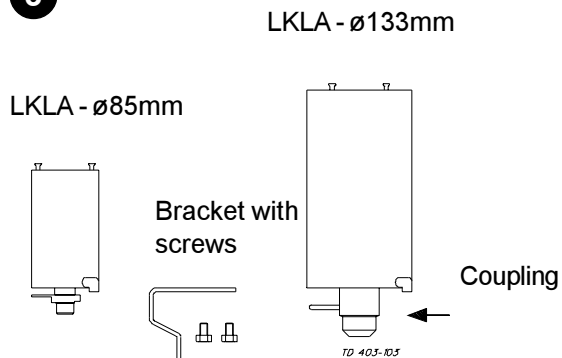

### Delivery of actuator and bracket:

1. Complete actuator with coupling and activating ring (ø85mm) or indication pin (ø133mm).
2. Bracket with screws for the actuator.

**4**

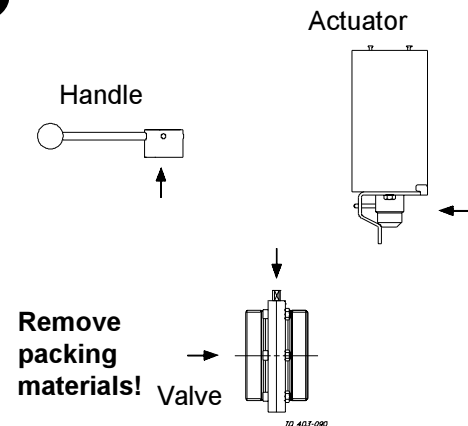

1. Clean the valve/valve parts for possible packing materials.
2. Clean the handle or the actuator, if supplied.

**5**

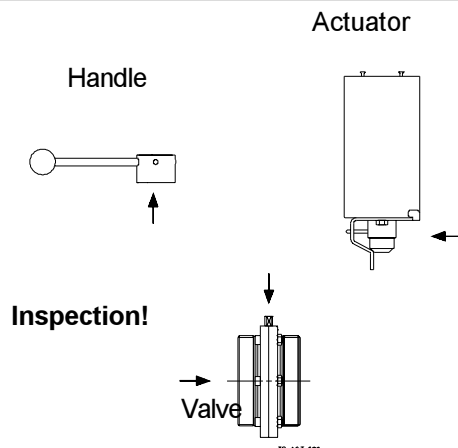

1. Inspect the valve/valve parts for visible transport damages.
2. Inspect the handle or the actuator, if supplied.

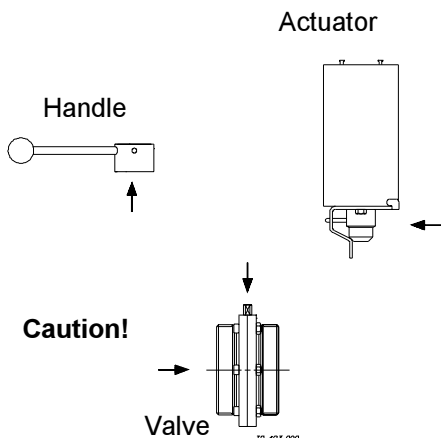

1. Avoid damaging the valve/valve parts.
2. Avoid damaging the handle or the actuator, if supplied.

Study the instructions carefully.  
The valve has welding ends as standard but can also be supplied with fittings (not LKB-F).

NC = Normally closed.  
NO = Normally open.  
A/A = Air/air activated.

## 2. General installation

1



- **Always** observe the technical data (see page 20).
- **Always** release compressed air after use.
- **Never** touch the coupling between the valve body and the actuator if compressed air is supplied to the actuator.

### NOTE!

We cannot be held responsible for incorrect installation.

2

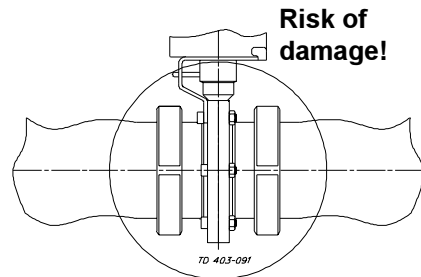

Avoid stressing the valve.

Pay special attention to:

- Vibrations.
- Thermal expansion of the tubes.
- Excessive welding.
- Overloading of the pipelines.

3

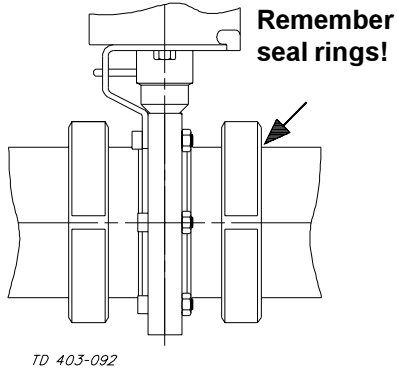

### Fittings:

Ensure that the connections are tight.

4

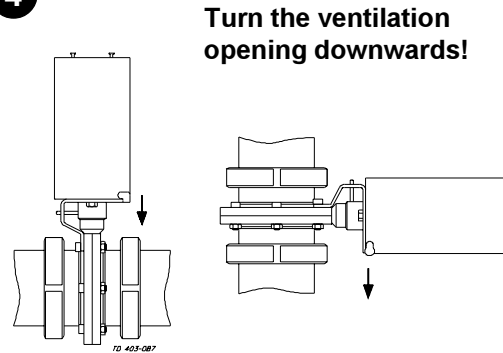

### Position of actuator:

Position the water rejector on the actuator correctly. (The actuator can be installed in any position).

5

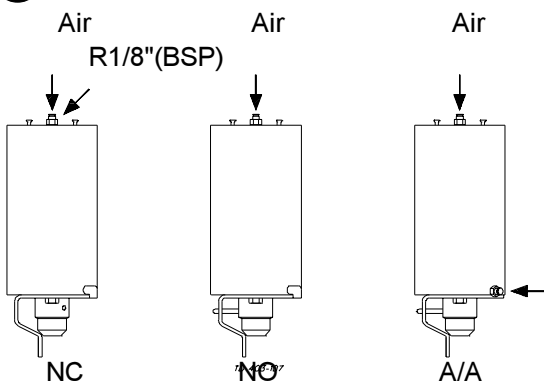

### Air connection of actuator:

Connect compressed air correctly.

**Pay special attention to the warnings!**

6

### Pre-use check:

Open and close the valve several times to ensure that the valve disc moves smoothly against the sealing.

**Pay special attention to the warnings!**

# Installation

6

Study the instructions carefully.  
The valve is supplied as separate parts to facilitate the welding.

LKB: For ISO tubes.  
LKB-2: For DIN tubes.  
LKB-F: With flange connection.

## 3. Welding - LKB/LKB-2

1. Weld the valve body halves into the pipelines.
2. Maintain the minimum clearance (A) so that the actuator can be removed.
3. If welding both valve body halves, ensure that they can be moved axially  $B_1$  mm, so that the valve parts can be removed.
4. Assemble the valve in accordance with the instructions 1-5 on page 15 after the welding.

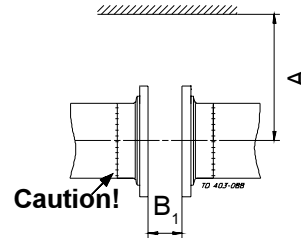

A(mm)	Ø85		Ø133	
	LKLA	LKLA-T	LKLA	LKLA-T
1"	245			
1½"	245			
2"	255			
2½"	265			
3"	265			
4"	290	+172	420	+172
DN25	245	(incl. top unit)		(incl. top unit)
DN32	245			
DN40	250			
DN50	260			
DN65	270			
DN80	275			
DN100	290		420	
DN125	315		440	
DN250	325		445	

## 3. Welding - LKB-F

1. Weld the flanges into the pipelines.
2. Maintain the minimum clearances (A and  $B_2$ ) so that the actuator and the valve parts can be removed.
3. Assemble the valve in accordance with the instructions 1-5 on page 17 after the welding.

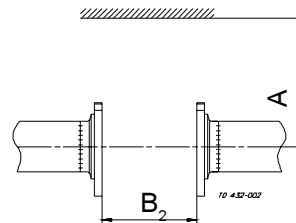

	$B_1$ (mm)	$B_2$ (mm)
1"	20	43
1½"	20	43
2"	20	47
2½"	24	46
3"	24	59
4"	37	59
DN25	20	43
DN32	20	43
DN40	20	43
DN50	20	47
DN65	24	59
DN80	23	59
DN100	37	59
DN125	40	63
DN250	41	79

### Pre-use check - LKB/LKB-2/LKB-F:

Open and close the valve several times to ensure that the valve disc moves smoothly against the seal ring.

**Pay special attention to the warnings!**



Study the instructions carefully and pay special attention to the warnings!

NC = Normally closed.  
 NO = Normally open.  
 A/A = Air/air activated.

## 4. Fitting actuator/bracket/handle on the valve (optional extras)

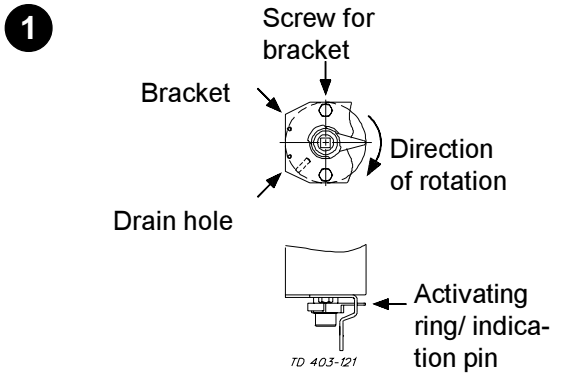

### Bracket/indication:

1. Fit the bracket as shown.
2. Fit and tighten the screws.
3. Fit the activating ring/indication pin as shown.

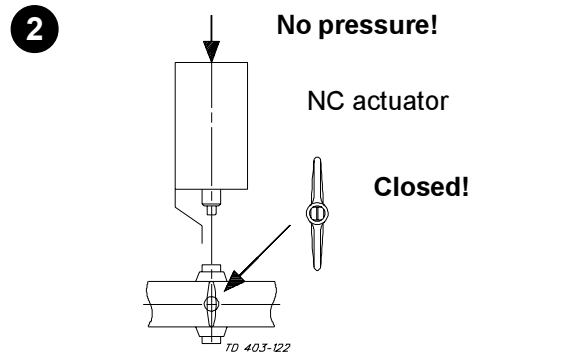

### Actuator/bracket - NC:

1. Ensure that the valve is closed by checking the position of the groove of the disc stem top.
2. Fit the actuator/bracket in accordance with instruction 4 on page 15.

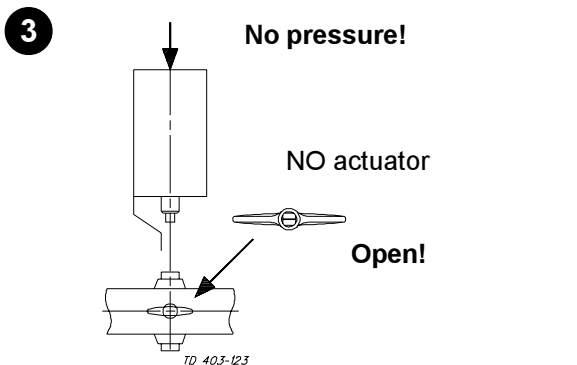

### Actuator/bracket - NO:

1. Ensure that the valve is open by checking the position of the groove of the disc stem top.
2. Fit the actuator/bracket in accordance with instruction 4 on page 15.

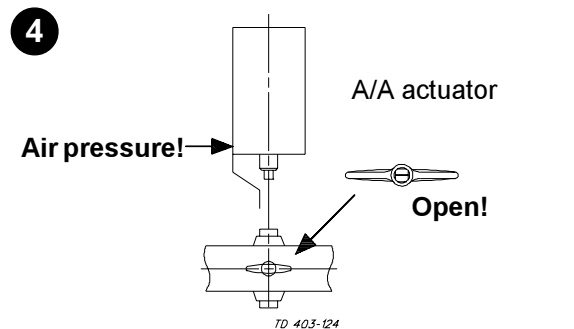

### Actuator/bracket - A/A:

1. Ensure that the valve is open by checking the position of the groove of the disc stem top.
2. Supply compressed air to the actuator.
3. Fit the actuator/bracket in accordance with instruction 4 on page 15.

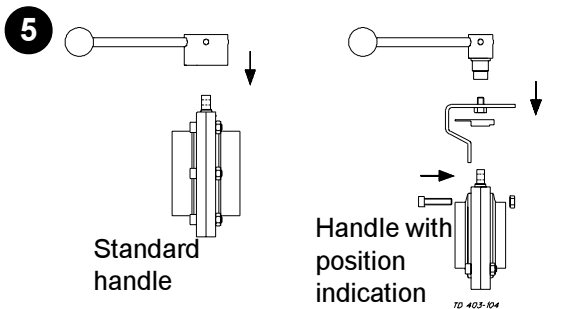

### Handle/indication:

1. Fit the standard handle on the valve so that the screw can enter the hole in the disc connection.
2. Fit the handle with position indication as shown and in accordance with the instructions 3-4 on page 15.



### Pre-use check:

Open and close the valve several times to ensure that it operates smoothly.

**Pay special attention to the warnings!**

# Installation

8

Study the instructions carefully.  
LKLA-T: For top units LKT-N and LKT-S.

Activating ring: For  $\varnothing 85\text{mm}$  actuator.  
Indication pin: For  $\varnothing 133\text{mm}$  actuator.  
Activating screw: For  $\varnothing 133\text{mm}$  actuator.

## 5. Indication and control equipment (optional extras)

1

### CAUTION!

The indication and control equipment must be electrically installed by authorized personnel.

- Indication unit:  
(See the instructions on the unit and on the packing).
- **ThinkTop**<sup>®</sup>:  
(See the separate instruction manuals).

2

LKLA -  $\varnothing 133\text{mm}$

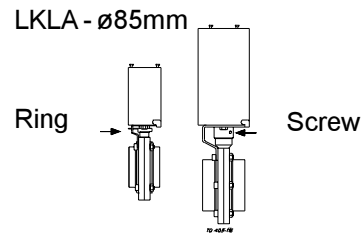

1. Fit the bracket, the activating ring/indication pin and the actuator/handle correctly before installing the indication unit.  
**Pay special attention to the warnings!**  
(See instructions 1-6 on page 7).
2. Fit the activating screw correctly ( $\varnothing 133\text{mm}$ ).

3

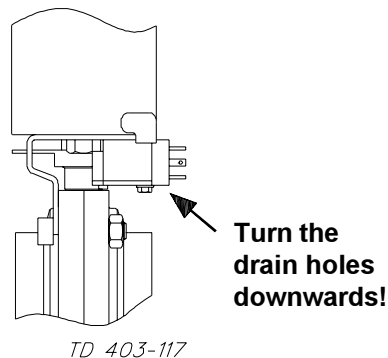

1. Fit the indication unit on the bracket.
2. Tighten the screws.

4

### NOTE!

Assemble the cable socket as shown on the plastic bag.

Parts: (See the plastic bag)

1. Gland screw.
2. Gland washer.
3. Seal ring.
4. Hood.
5. Insert.
6. Screw.
7. Seal.

5

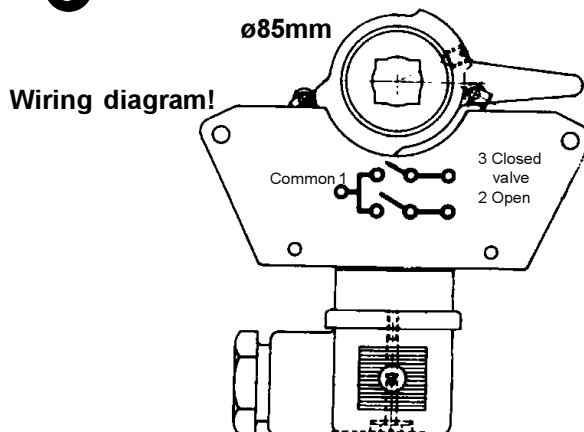

Connect the cable as shown in the wiring diagram on the indication unit.

6

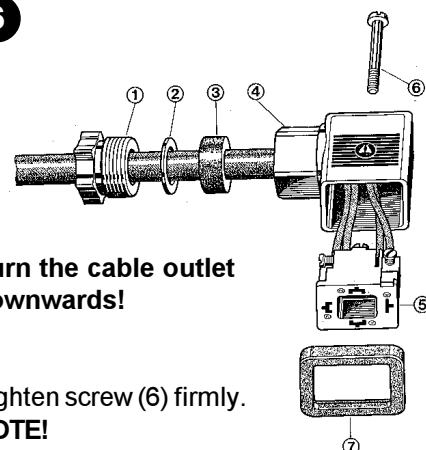

Turn the cable outlet downwards!

Tighten screw (6) firmly.

### NOTE!

The cable gland with seal ring (3) should be sealed with silicone rubber under extreme conditions.

Study the instructions carefully and pay special attention to the warnings!

The valve is automatically or manually operated by means of an actuator or a handle.

## 1. Operation

1

 **Always** observe the technical data (see page 20).

**NOTE!**  
We cannot be held responsible for incorrect operation.

2

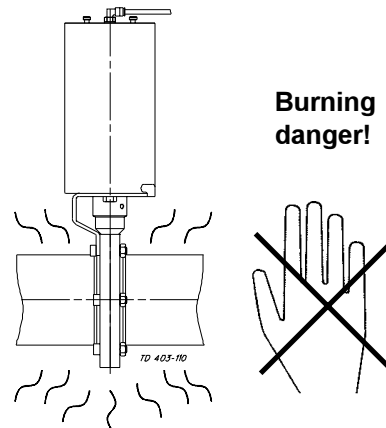

**Burning danger!**

 **Never touch the valve or the pipelines when processing hot liquids or when sterilizing.**

3

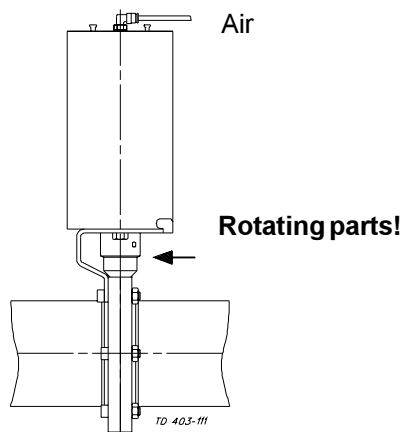

 **Never touch the coupling between the valve body and the actuator if compressed air is supplied to the actuator.**

4

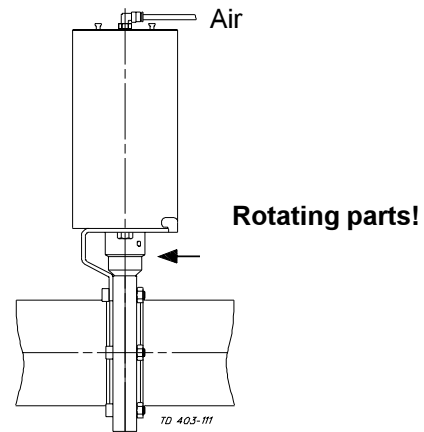

**Operation by means of actuator:**  
Automatic on/off operation by means of compressed air.

5

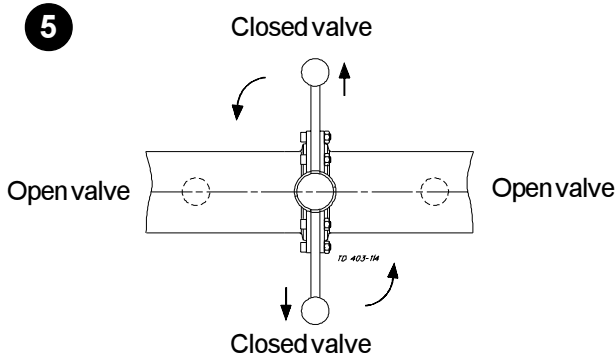

**Operation by means of standard handle:**

1. Manual on/off operation.
2. Pull the handle outwards while rotating it.

**NOTE!**  
This also applies for the Lockable Multiposition Handle.

6

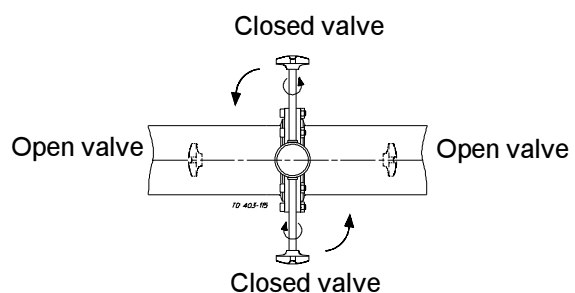

**Operation by means of regulating handle:**

1. Manual flow regulation because of infinite locking positions.
2. Loosen the handle, rotate it and tighten again.

Pay attention to possible break-down.  
 Study the instructions carefully.  
 LKB-F: With flange connection.

NC = Normally closed.  
 NO = Normally open.  
 A/A = Air/air activated.

## 2. Fault finding

**NOTE!**

Study the maintenance instructions carefully before replacing worn parts. - See page 11!

Problem	Cause/result	Repair
<ul style="list-style-type: none"> <li>- External leakage</li> <li>- Internal leakage by closed valve (normal wear)</li> </ul>	<ul style="list-style-type: none"> <li>- Worn seal ring</li> <li>- Worn flange seal ring (LKB-F)</li> </ul>	Replace the seal ring and the bushes
<ul style="list-style-type: none"> <li>- External leakage</li> <li>- Internal leakage by closed valve (too early)</li> </ul>	<ul style="list-style-type: none"> <li>- High pressure</li> <li>- High temperature</li> <li>- Aggressive liquids</li> <li>- Many activations</li> </ul>	<ul style="list-style-type: none"> <li>- Replace by a seal ring of a different rubber grade</li> <li>- Change the operation conditions</li> </ul>
<ul style="list-style-type: none"> <li>- Difficult to open/close</li> <li>- Damage of disc connection (high torque)</li> </ul>	Incorrect seal ring (swelling)	Replace by a seal ring of a different rubber grade
Difficult to open/close	<ul style="list-style-type: none"> <li>- 90° displacement of the actuator</li> <li>- Incorrect actuator function (NC,NO)</li> <li>- Worn actuator bearings</li> <li>- Dirt penetration into the actuator</li> </ul>	<ul style="list-style-type: none"> <li>- Fit correctly (see page 7)</li> <li>- Change from NC to NO or vice versa</li> <li>- Replace the bearings</li> <li>- Service the actuator</li> </ul>

The valve is designed for cleaning in place (CIP).  
CIP = Cleaning In Place.

Study the instructions carefully and pay special attention to the warnings!  
NaOH = Caustic Soda.  
HNO<sub>3</sub> = Nitric acid.

### 3. Recommended cleaning

#### 1 Caustic danger!

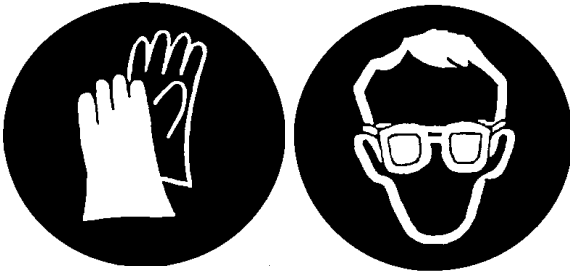

Always use rubber gloves!

Always use protective goggles!

 Always handle lye and acid with great care.

#### 3

**Examples of cleaning agents:**  
Use clean water, free from chlorides.

1. 1% by weight NaOH at 70°C.

1 kg NaOH	+	100 l water	= Cleaning agent.
--------------	---	----------------	-------------------

2.2 l 33% NaOH	+	100 l water	= Cleaning agent.
-------------------	---	----------------	-------------------

2. 0.5% by weight HNO<sub>3</sub> at 70°C.

0.7 l 53% HNO <sub>3</sub>	+	100 l water	= Cleaning agent.
-------------------------------	---	----------------	-------------------

#### 5

Always!

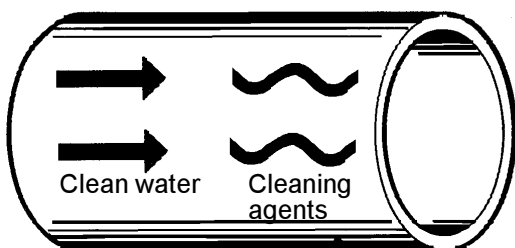

Always rinse well with clean water after the cleaning.

#### 2

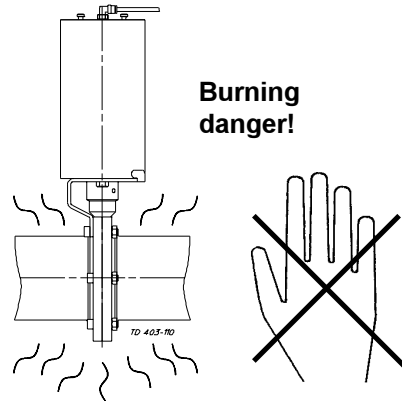

 Never touch the valve or the pipelines when sterilizing.

#### 4

1. Avoid excessive concentration of the cleaning agent

⇒ Dose gradually!

2. Adjust the cleaning flow to the process

⇒ Sterilization of milk/viscous liquids

⇒ Increase the cleaning flow!

#### 6

**NOTE!**

The cleaning agents must be stored/discharged in accordance with current rules/directives.

# Maintenance

12

Maintain the valve and the actuator carefully.  
Study the instructions carefully and pay special attention to the warnings!

Always keep spare seal rings, rubber seals, bushes and actuator bearings in stock.  
"Mushrooms" = Fastening connections on the end cap.

## 1. General maintenance

1

- ⚠ - **Always** observe the technical data (see page 20).
- **Always** release compressed air after use.

### NOTE!

All scrap must be stored/discharged in accordance with current rules/directives.

2

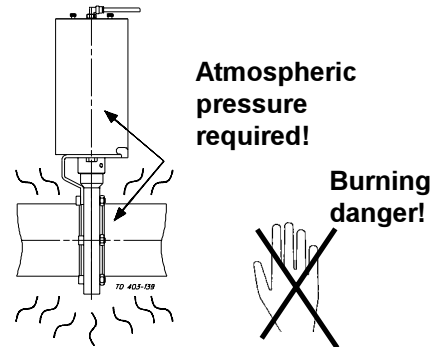

- ⚠ - The valve must **never** be hot when servicing it.
- The valve/actuator and the pipelines must **never** be pressurised when servicing the valve/actuator.

3

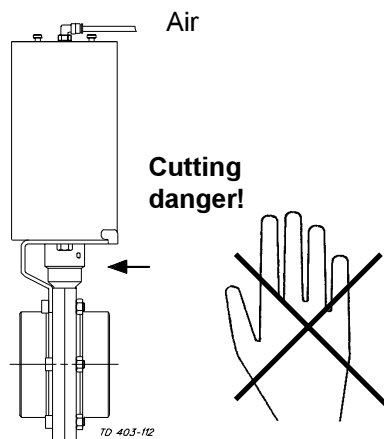

- ⚠ **Never** stick your fingers through the valve ports if compressed air is supplied to the actuator.

4

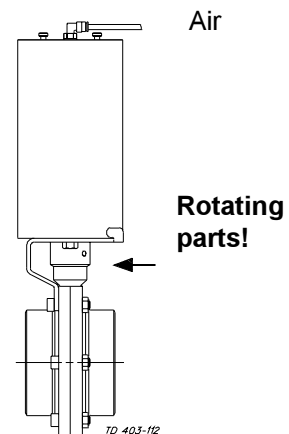

- ⚠ **Never** touch the coupling between the valve body and the actuator if compressed air is supplied to the actuator.

5

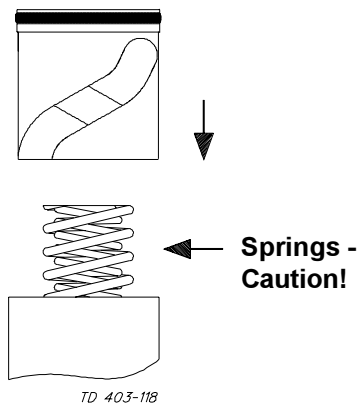

- ⚠ **Actuator size  $\varnothing 85\text{mm}$  (NC/NO):**  
The actuator springs are **not** caged.

6

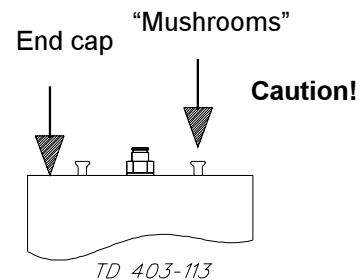

- ⚠ **End cap of actuator:**
  - **Never** remove the end cap by using compressed air.
  - **Always** fit the end cap with the "mushrooms" turned outwards and position it correctly before supplying compressed air to the actuator.

Maintain the valve and the actuator carefully.  
Study the instructions carefully.

Always keep spare seal rings, rubber seals, bushes  
and actuator bearings in stock.

## 1. General maintenance

### Ordering spare parts

- Contact the Sales Department.
- Order from the Spare Parts List.

**Recommended spare parts: Service kits (see Spare Parts List).**

	Valve seal rings	Valve bushes	Actuator rubber seals	Actuator bearings
Preventive maintenance	<b>Replace after 12 months</b>	Replace when replacing the valve seal rings	<b>Replace after 24 months</b>	
Maintenance after leakage (leakage normally starts slowly)	<b>Replace by the end of the day</b>	Replace when replacing the valve seal rings	<b>Replace when possible</b>	
Planned maintenance	<ul style="list-style-type: none"> <li>- Regular inspection for leakage and smooth operation</li> <li>- Keep a record of the valve</li> <li>- Use the statistics for planning of inspections</li> </ul> <b>Replace after leakage</b>	Replace when replacing the valve seal rings	<ul style="list-style-type: none"> <li>- Regular inspection for leakage and smooth operation</li> <li>- Keep a record of the actuator</li> <li>- Use the statistics for planning of inspections</li> </ul> <b>Replace after air leakage</b>	Replace when they become worn
Lubrication	<b>Before fitting</b> (use USDA-H1 approved) - Unisilcon L641(*) - Paraliq (*) GTE 703 - Molycote 111 (Δ)	<b>None</b>	<b>Before fitting</b> - Molycote Long term 2 Plus (Δ) - Molycote 1132(Δ) (for aggressive environment)	<b>When replacing actuator rubber seals</b> - Molycote Long term 2 Plus (Δ) - Molycote 1132 (Δ) (for aggressive environment)

(\*) Klüber lubrication

(Δ) Dow corning

# Maintenance

14

Study the instructions carefully.  
The items refer to the drawings and the parts list on the pages 22-25.

Handle scrap correctly.  
LKB: For ISO tubes.  
LKB-2: For DIN tubes.

## 2. Dismantling of valve - LKB/LKB-2

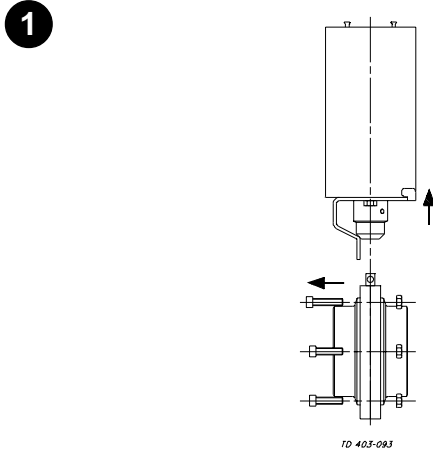

**Valve with actuator:**

1. Remove screws and nuts (6).
2. Remove the bracket with the actuator.

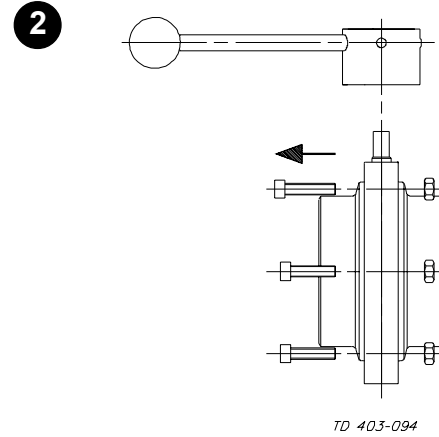

**Valve with handle:**

1. Remove the complete handle.
2. Remove screws and nuts (6).

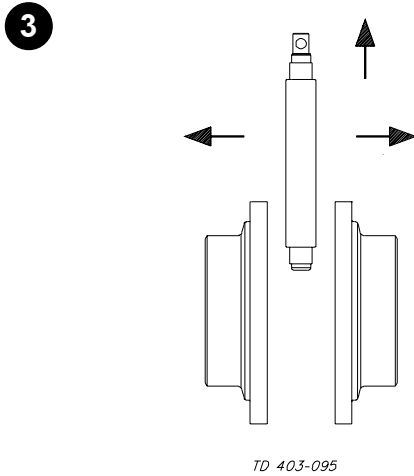

Remove seal ring (5) together with valve disc (2).

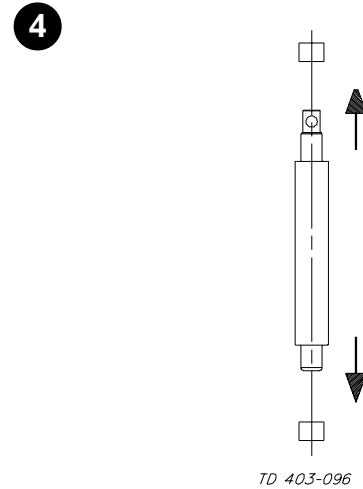

Remove bushes (3,4) from the disc stems.

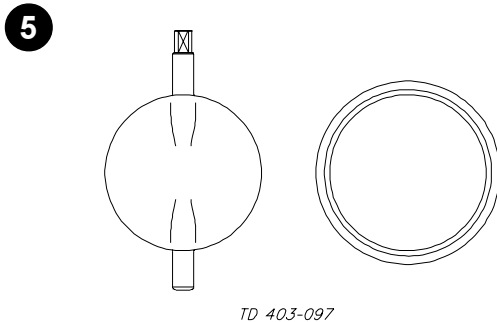

Remove valve disc (2) from seal ring (5).

**NOTE!**

For the valve sizes 25-38mm and DN25-40 it is recommended to remove the valve disc by using a special service tool.



Study the instructions carefully.  
The items refer to the drawings and the parts list on the pages 22-25.

LKB: For ISO tubes.  
LKB-2: For DIN tubes.  
Lubricate the seal ring before fitting it.  
Lubricate the disc stem before fitting the bushes.

## 3. Assembly of valve - LKB/LKB-2

1

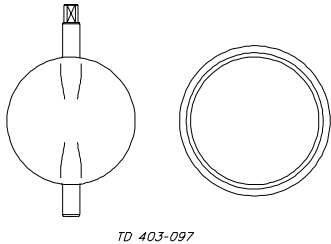

1. Lubricate the pin holes in seal ring (5), (important for Silicone and Viton).
2. Fit valve disc (2) in the seal ring (5).

**NOTE!**

For the valve sizes 25-38mm and DN25-40 it is recommended to fit the valve disc by using a special service tool.

2

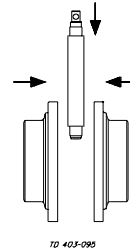

1. Fit bushes (3,4) on the disc stem.
2. Fit seal ring (5) together with valve disc (2) between the two valve body halves (1).

**CAUTION!**

Rotate the valve disc so that the valve is open before tightening screws and nuts (6).

3

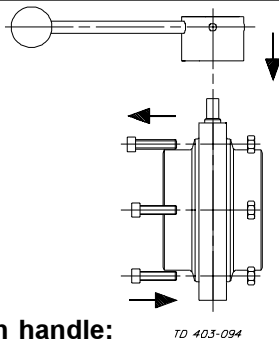

**Valve with handle:**

1. Fit screws and nuts (6) and torque tighten in accordance with the requirements (see 5).
2. Fit the complete handle on the disc connection and tighten the screw on the handle.

**NOTE!**

This also applies for the Lockable Multiposition Handle.

4

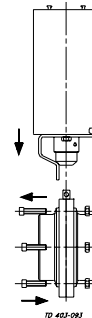

**Fit correctly!  
(See page 7)**

**Valve with actuator:**

1. Fit the actuator with the bracket so that the disc connection enters the coupling (see page 7).
2. Fit screws and nuts (6) and torque tighten in accordance with the requirements so that the bracket is fixed to the valve (see 5).

5

**Pre-use check:**

Check that the valve disc moves smoothly against the seal ring.

**Pay special attention to the warnings!**

Tools/torque values for assembly of the valve body halves:

Valve size	25mm DN 25	DN32	38mm DN40	51mm DN50	63.5mm DN65	76mm DN80	101.6mm DN100	DN125	DN150
Allen Key Recomm.Torque	5mm 18Nm	5mm 18Nm	5mm 18Nm	6mm 20Nm	6mm 20Nm	6mm 20Nm	8mm 38Nm	8mm 38Nm	8mm 38Nm

# Maintenance

16

Study the instructions carefully.  
The items refer to the drawings and the parts list on the pages 22-25.

Handle scrap correctly.  
LKB-F: With flange connection.

## 4. Dismantling of valve - LKB-F

1

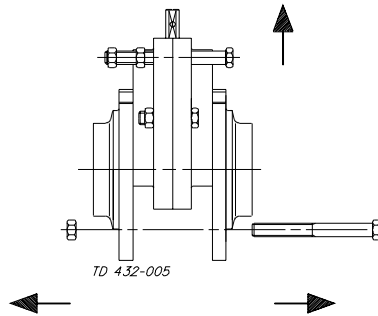

1. Loosen the two upper screws and nuts (6).
2. Loosen and remove the two lower screws and nuts (6).
3. Remove the valve unit from flanges (7).

2

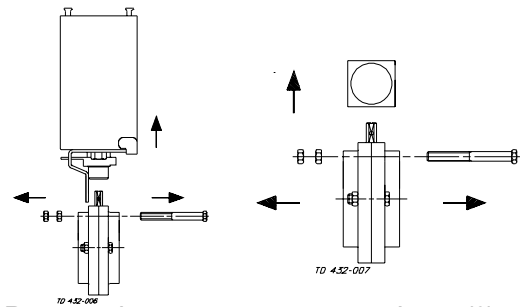

1. Remove the two upper screws and nuts (6), (4 nuts)
2. If supplied, remove the actuator from the valve body unit.
3. If supplied loosen the screw and remove the handle from the valve body unit.

3

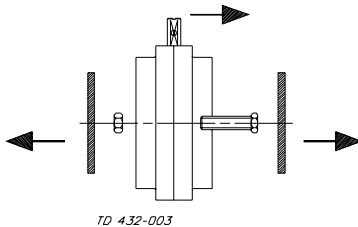

1. Loosen and remove the two center screws and nuts (6).
2. Remove seal ring (5) together with valve disc (2).
3. Remove flange seal rings (8).

4

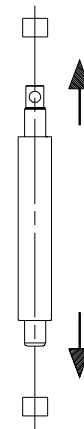

Remove bushes (3,4) from the disc stems.

5

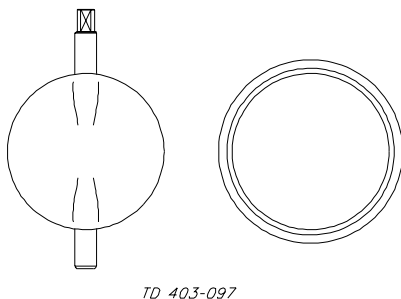

Remove valve disc (2) from seal ring (5).

### NOTE!

For the valve sizes 25-38mm and DN25-40 it is recommended to remove the valve disc by using a special service tool.

Study the instructions carefully.  
The items refer to the drawings and the parts list on the pages 22-25.

LKB-F: With flange connection,  
Lubricate the seal rings before fitting them.  
Lubricate the disc stem before fitting the bushes.

## 5. Assembly of valve - LKB-F

1

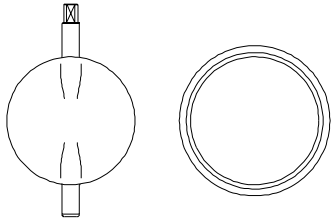

1. Lubricate the pin holes in seal ring (5), (important for Silicone and Viton).
2. Fit valve disc (2) on seal ring (5).
3. Fit bushes (3,4) in the disc stem.

**NOTE!**

For the valve size 25-38mm and DN25-40 it is recommended to fit the valve disc by using a special service tool.

2

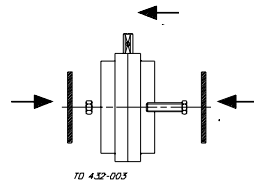

1. Lubricate flange seal rings (8) with water and fit them.
2. Fit seal ring (5) together with valve disc (2) between the valve body halves (1).
3. Fit and tighten the two center screws and nuts (6).

**CAUTION!**

Rotate the valve disc so that the valve is open before tightening screws and nuts (6).

3

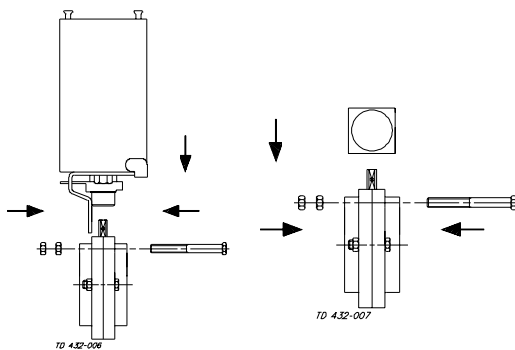

1. If supplied, fit the handle and tighten the screw.
2. If supplied, fit the actuator.
3. Fit the two upper screws and nuts (6), (4 nuts).

4

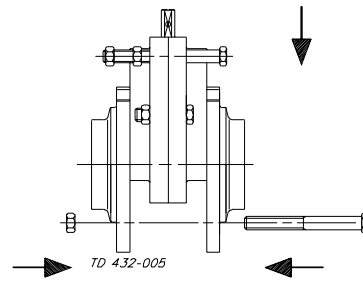

1. Fit the valve unit between flanges (7).
2. Fit and tighten the two lower screws and nuts (6).
3. Tighten the two upper screws and nuts (6).

5

**Pre-use check:**

Check that the valve disc moves smoothly against the seal ring.

**Pay special attention to the warnings!**

Tools/torque values for assembly of the valve body halves:

Valve size	25mm DN 25	DN32	38mm DN40	51mm DN50	63.5mm DN65	76mm DN80	101.6mm DN100	DN125	DN150
Spanner flats	10mm	10mm	10mm	13mm	13mm	13mm	17mm	17mm	17mm
Recomm.Torque	18Nm	18Nm	18Nm	20Nm	20Nm	20Nm	38Nm	38Nm	38Nm

# Maintenance

18

Study the instructions carefully.  
The items refer to the drawings and the parts lists on the pages 30-37.

Handle scrap correctly.  
NC = Normally closed.  
NO = Normally open.  
A/A = Air/air activated.

## 6. Dismantling of actuator

1

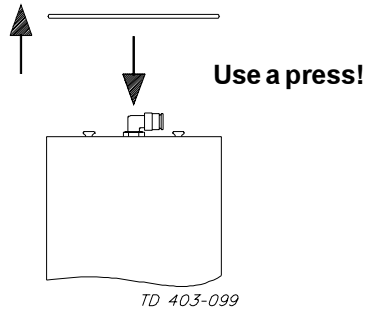

1. Press end cap (5) into air cylinder (1).
2. Remove retaining ring (6).

2

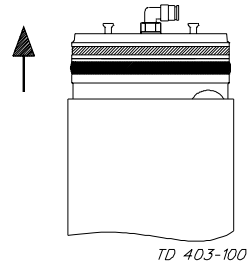

### NC/NO actuator:

Release the pressure on end cap (5) carefully and remove the end cap.

**Pay special attention to the warning!**

3

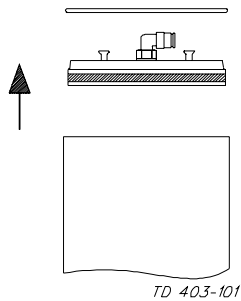

### A/A actuator:

Remove end cap (5) by hand.

**Pay special attention to the warning!**

4

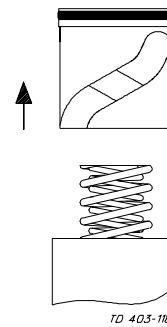

Remove piston (3) and the springs.

### NOTE!

- The actuator size  $\varnothing 133\text{mm}$  has a caged spring assembly.
- The air/air actuator has no springs.

5

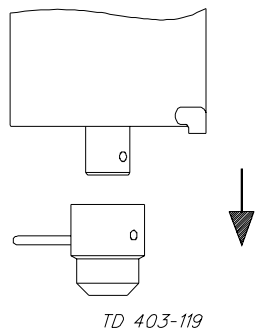

Remove connex pin (16) and coupling (17) from rotating cylinder stem (2).

6

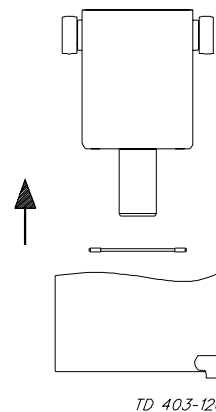

Remove rotating cylinder (2) and the remaining internal parts from air cylinder (1).

Study the instructions carefully.  
 NC = Normally closed.  
 NO = Normally open.  
 A/A = Air/air activated.

Lubricate the rubber seals before fitting them.  
 Lubricate the bearings.  
 Clean the piston before assembly.

## 7. Assembly of actuator

1

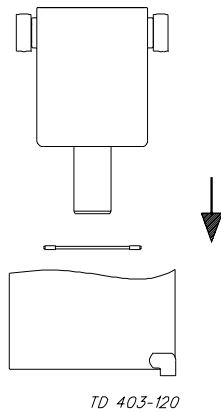

Fit rotating cylinder (2) in air cylinder (1).

2

Fit the connex pin correctly!

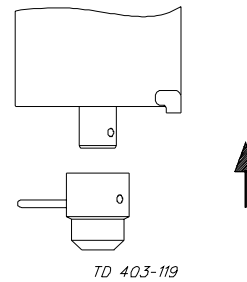

Fit coupling (17) on rotating cylinder stem (2) and fit connex pin (16).

3

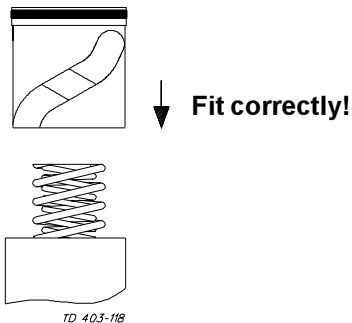

Fit the springs in rotating cylinder (2) and fit piston (3) carefully.

**CAUTION!**  
 Fit the piston correctly in relation to the bearings.

**NOTE!**  
 The air/air actuator is has no springs.

4

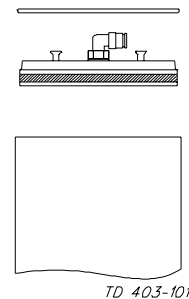

**A/A actuator:**

1. Fit end cap (5) sufficiently into air cylinder (1) so that retaining ring (6) can be fitted in the air cylinder.
2. Position the end cap correctly by hand.  
**Pay special attention to the warning!**

5

Use a press!

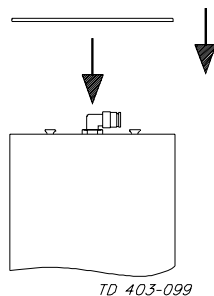

**NC/NO actuator**

1. Fit end cap (5) in air cylinder (1) and press sufficiently down so that retaining ring (6) can be fitted in the air cylinder.
2. Release the pressure on the end cap.  
**Pay special attention to the warning!**

6

**Pre-use check:**

1. Supply compressed air to the actuator.
2. Activate the actuator several times to ensure that it operates smoothly.  
**Pay special attention to the warnings!**

# Technical data

*It is important to observe the technical data during installation, operation and maintenance.*

*Inform the personnel about the technical data.*

*NC = Normally closed.*

*NO = Normally open.*

*A/A = Air/air activated.*

20

## 1. Technical data

---

### Valve - data

---

Max. product pressure ..... 1000kPa (10bar)

Min. product pressure ..... Full vacuum

Temperature range ..... -10° C to +95° C

---

### Valve - materials

---

Product wetted steel parts ..... AISI 304 or AISI 316L

Other steel parts ..... AISI 304

Rubber grades ..... EPDM, Silicone (Q) or Viton (FPM)

Bushes for valve disc ..... PVDF

Finish ..... Semi bright

---

### Actuator - data

---

Max. air pressure ..... 700kPa (7bar)

Min. air pressure, NC or NO ..... 400kPa (4bar)

Temperature range ..... -25° C to +90° C

Air consumption (litres free air) - ø85 mm ..... 0.24 x p (bar)

- ø133 mm ..... 0.95 x p (bar)

---

### Actuator - materials

---

Actuator body ..... AISI 304

Piston ..... Light alloy, bronze for ø85mm A/A

Seals ..... Nitrile (NBR)

Housing for switches ..... Noryl (PPO)

Finish ..... Semi bright

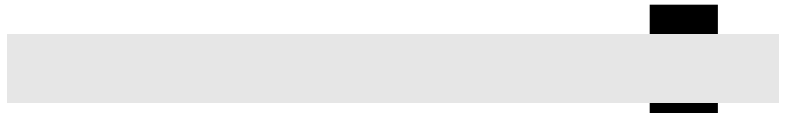

# Drawing/Parts list

The drawings and the parts list include all items.

The items are identical with the items in the Spare Parts list.

When ordering spare parts, please use the Spare Parts List!

## Parts list LKB/LKB-2/LKB-F

22

Item	Qty.	Denomination
1	2	Valve body half, welding
1a	2	Valve body half, male
2	1	Valve disc
3Δ	1	Bush
4Δ	1	Bush
5Δ	1	Seal ring
6	1	Set of screws and nuts
7	2	Flange
8Δ	2	Flange seal ring

Δ: Service Kit - EPDM, Q, FPM  
(See Spare Parts List)



This page shows exploded drawings of LKB, LKB-2 and LKB-F.

LKB: For ISO tubes.

LKB-2: For DIN tubes.

LKB-F: With flange connection.

The drawings include all items of the valve.

They are identical with the items in the Spare Parts List

## Exploded drawings

### LKB

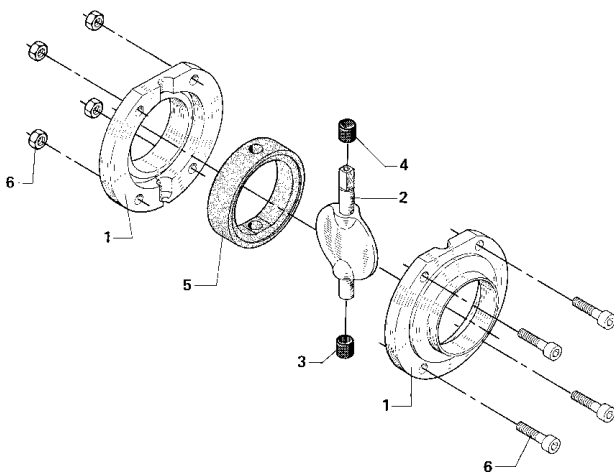

### LKB-2

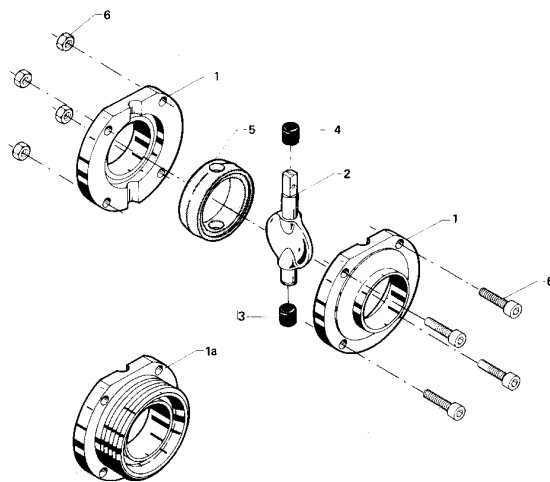

### LKB-F

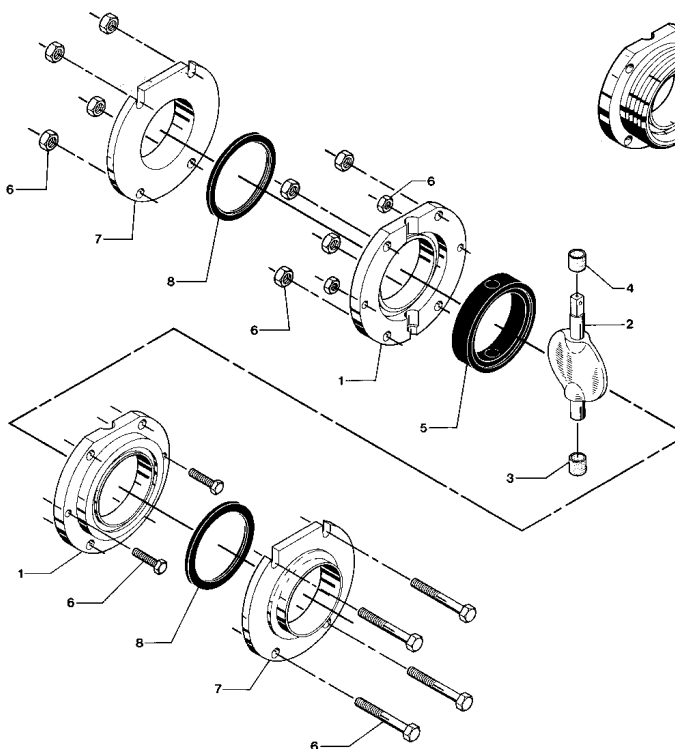

# Drawing/Parts list

The drawings and the parts list include all items.

The items are identical with the items in the Spare Parts list.

When ordering spare parts, please use the Spare Parts List!

## Parts list LKB/LKB-2/LKB-F

24

Item	Qty.	Denomination
1	2	Valve body half, welding
1a	2	Valve body half, male
2	1	Valve disc
3Δ	1	Bush
4Δ	1	Bush
5Δ	1	Seal ring
6	1	Set of screws and nuts
7	2	Flange
8Δ	2	Flange seal ring

Δ: Service Kit - EPDM, Q, FPM  
(See Spare Parts List)

The drawings below show LKB-2, LKB-F and LKB-F.  
LKB: For ISO tubes.  
LKB-2: For DIN tubes.  
LKB-F: With flange connection.

The items refer to the parts list on the opposite part of the page.

## Drawings

### LKB/LKB-2

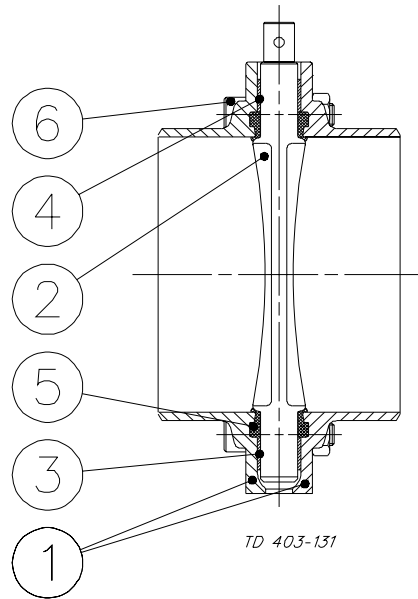

### LKB-F

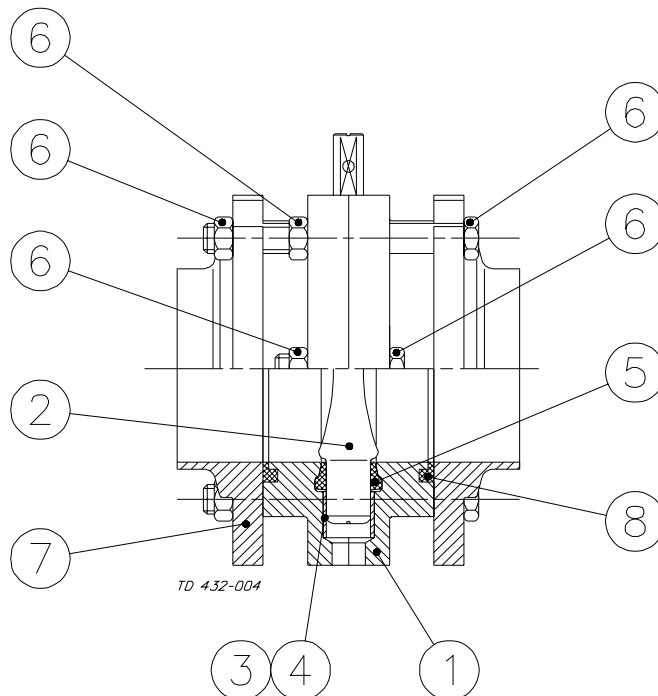

## Drawing/Parts list

The drawings and the parts list include all items.

The items are identical with the items in the Spare Parts list.

When ordering spare parts, please use the Spare Parts List!

### Parts list Handles

26

**Standard handle, handle for indication unit and regulating handle with infinite positions:**

Item	Qty.	Denomination
1	1	Location cap
1a	1	Location cap with 2 pos.
1b	1	Location cap with 4 pos.
2	1	Transfer block
3	1	Handle
4	1	Screw with pin
5	1	Spring
6	1	Ball
7	1	Crosshead
8	1	Bracket
9	1	Screw
10	1	Coupling
11	1	Activating ring with screw

**Lockable Multiposition Handle:**

Item	Qty.	Denomination
1	1	Insert
2	1	Location cap (76-101.6 mm/DN65-100)
		Location cap (25-63.5 mm/DN25-50)
3	1	Screw

This page shows exploded drawings of the standard handle, the handle for indication unit, the regulating handle and the Lockable Multiposition Handle.

The drawings include all items of the handles. They are identical with the items in the Spare Parts List.

## Exploded drawings

### Standard handle

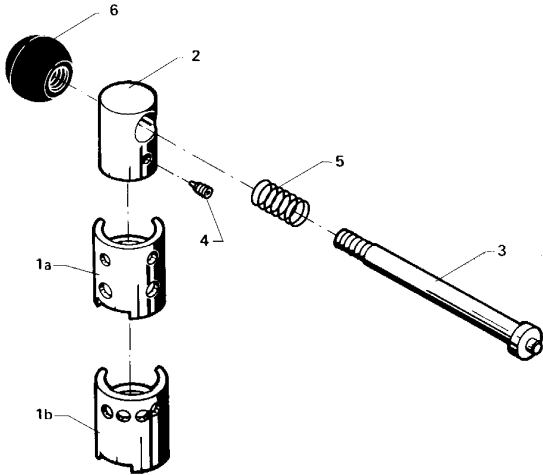

### Handle for indication unit

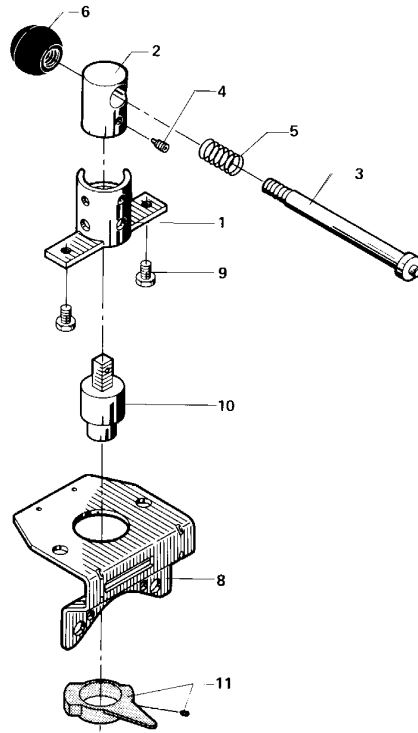

### Regulating handle with infinite positions

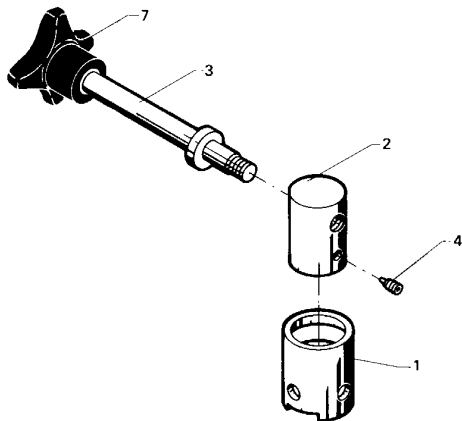

### Lockable Multiposition Handle

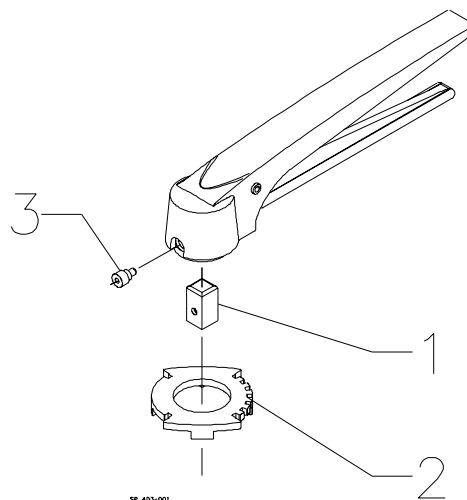

SP 403-001

## Drawing/Parts list

The drawings and the parts list include all items.

The items are identical with the items in the Spare Parts list.

When ordering spare parts, please use the Spare Parts List!

### Parts list Handles

28

**Standard handle, handle for indication unit and regulating handle with infinite positions:**

Item	Qty.	Denomination
1	1	Location cap
1a	1	Location cap with 2 pos.
1b	1	Location cap with 4 pos.
2	1	Transfer block
3	1	Handle
4	1	Screw with pin
5	1	Spring
6	1	Ball
7	1	Crosshead
8	1	Bracket
9	1	Screw
10	1	Coupling
11	1	Activating ring with screw

**Lockable Multiposition Handle:**

Item	Qty.	Denomination
1	1	Insert
2	1	Location cap (76-101.6 mm/DN65-100)
		Location cap (25-63.5 mm/DN25-50)
3	1	Screw

The drawings below show the handles.

The items refer to the parts lists on the opposite part of the page.

## Drawings

### Standard handle

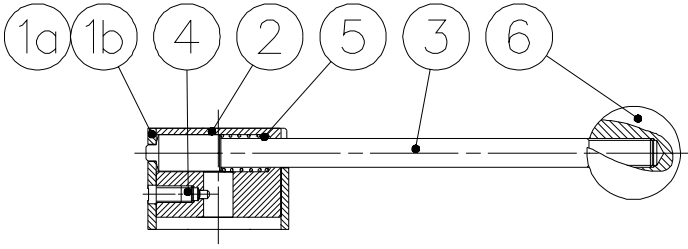

TD 403-126

### Handle for indication unit

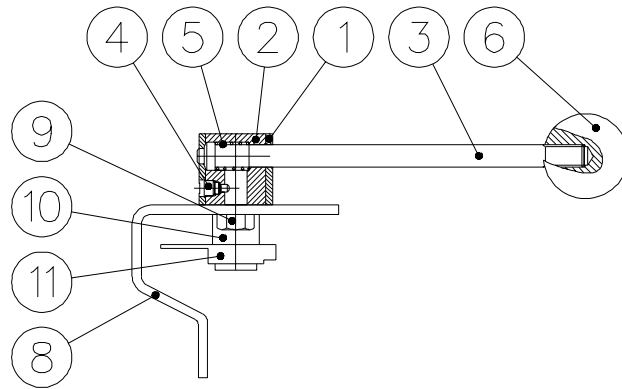

TD 403-128

### Regulating handle with infinite positions

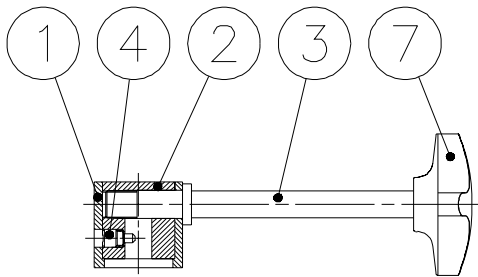

TD 403-127

### Lockable Multiposition Handle

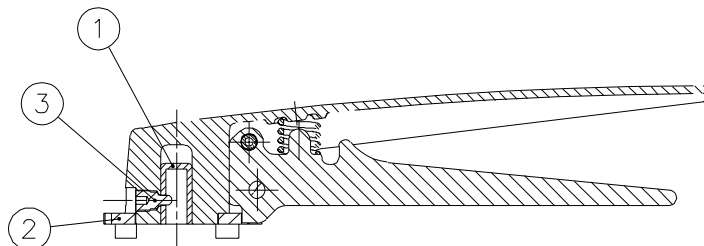

TD 403-203

## Drawing/Parts list

The drawings and the parts list include all items.

The items are identical with the items in the Spare Parts list.

When ordering spare parts, please use the Spare Parts List!

### Parts list

#### LKLA/LKLA-T, ø85mm, NC-NO-A/A

30

Item	Qty.	Denomination
1	1	Air cylinder
2	1	Rotating cylinder
3	1	Piston
4Δ	1	O-ring
5	1	End cap
6	1	Retaining ring
7Δ	1	O-ring
8	1	Inner spring
9	1	Outer spring
10Δ	2	Needle bearing
11Δ	2	Needle bearing
12Δ	1	Thrust bearing (A/A)
	2	Thrust bearing (NC/NO)
13	1	Connex pin
14	1	Thrust plate
15Δ	1	O-ring
16	1	Connex pin
17	1	Coupling
18	1	Activating ring
19	1	Water rejector
20Δ	1	O-ring
21	1	Air fitting
22	1	Retaining plate
23	1	Threaded plug

Δ: Service Kit  
(See Spare Parts List)



This page shows an exploded drawing of LKLA/  
LKLA-T, size ø85 mm.  
NC = Normally closed.  
NO = Normally open.

A/A = Air/Air activated  
The drawing includes all items of the actuator.  
They are identical with the items in the Spare Parts  
List.

## Exploded drawing

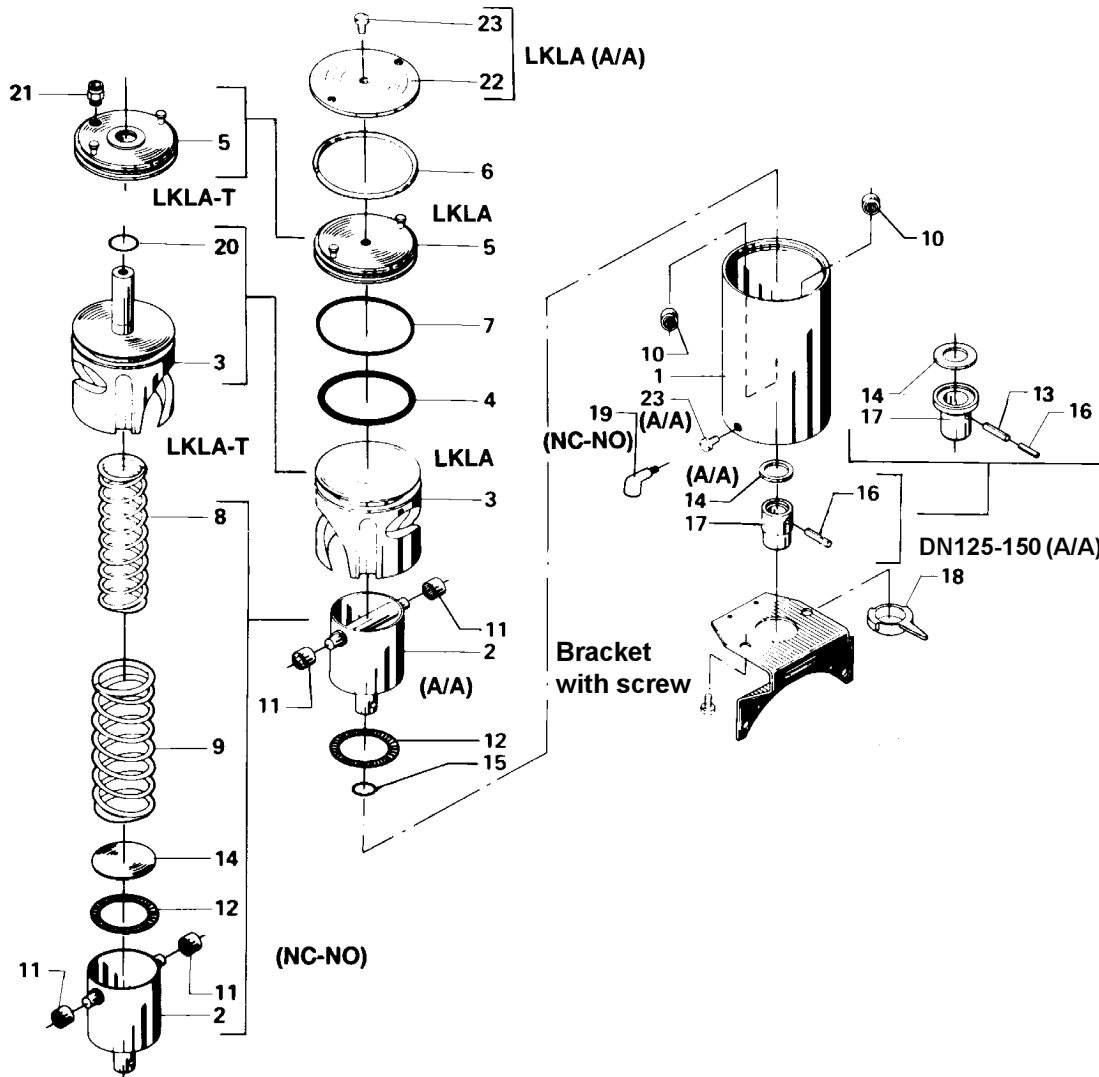

## Drawing/Parts list

The drawings and the parts list include all items.

The items are identical with the items in the Spare Parts list.

When ordering spare parts, please use the Spare Parts List!

### Parts list

#### LKLA/LKLA-T, ø85mm, NC-NO-A/A

32

Item	Qty.	Denomination
1	1	Air cylinder
2	1	Rotating cylinder
3	1	Piston
4Δ	1	O-ring
5	1	End cap
6	1	Retaining ring
7Δ	1	O-ring
8	1	Inner spring
9	1	Outer spring
10Δ	2	Needle bearing
11Δ	2	Needle bearing
12Δ	1	Thrust bearing (A/A)
	2	Thrust bearing (NC/NO)
13	1	Connex pin
14	1	Thrust plate
15Δ	1	O-ring
16	1	Connex pin
17	1	Coupling
18	1	Activating ring
19	1	Water rejector
20Δ	1	O-ring
21	1	Air fitting
22	1	Retaining plate
23	1	Threaded plug

Δ: Service Kit  
(See Spare Parts List)

The drawings below show LKLA/LKLA-T,  $\varnothing 85$  mm, NC-NO-A/A.

NC = Normally closed.

NO = Normally open.

A/A = Air/Air activated.

The items refer to the parts list on the opposite part of the page.

## Drawings

**LKLA-T (NC-NO)**

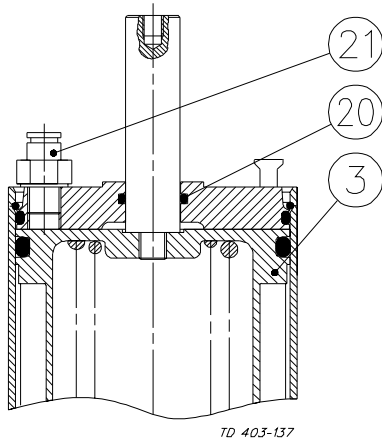

**LKLA-T (A/A)**

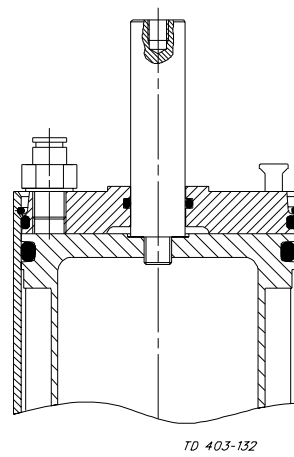

**LKLA (NC-NO)**

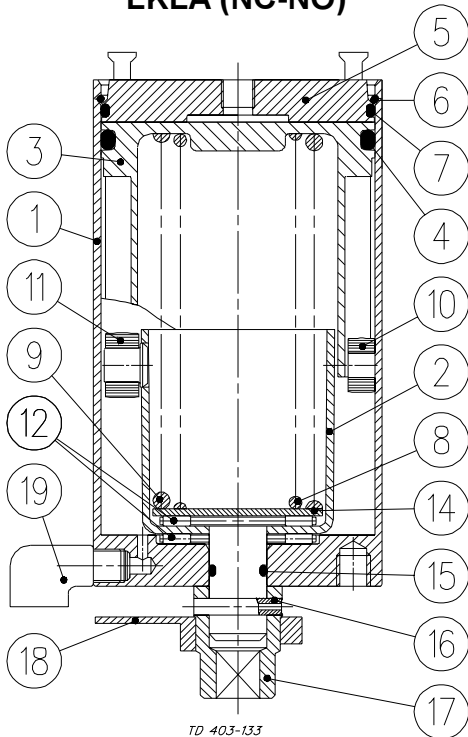

**LKLA (A/A)**

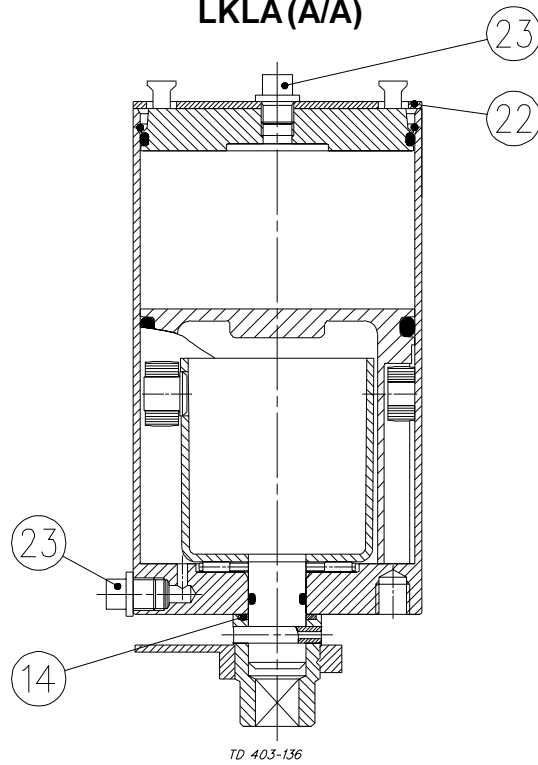

**DN 125-150 (A/A)**

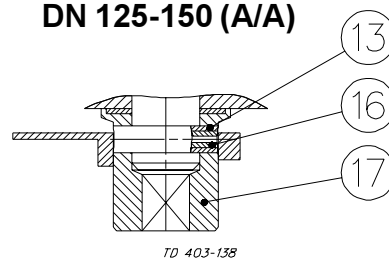

## Drawing/Parts list

The drawings and the parts list include all items.

The items are identical with the items in the Spare Parts list.

When ordering spare parts, please use the Spare Parts List!

### Parts list

#### LKLA/LKLA-T, ø133mm, NC-NO-A/A

34

Item	Qty.	Denomination
1	1	Air cylinder
2	1	Rotating cylinder
3	1	Piston
4Δ	1	O-ring
5	1	End cap
6	1	Retaining ring
7Δ	1	O-ring
8	1	Spring assembly
10Δ	2	Needle bearing
11Δ	2	Needle bearing
12Δ	1	Thrust bearing (A/A)
	2	Thrust bearing (NC/NO)
13	1	Connex pin (NC-NO)
	2	Connex pin (A/A)
14	1	Thrust plate
15Δ	1	O-ring
16	1	Connex pin (NC-NO)
	2	Connex pin (A/A)
17	1	Coupling
18	1	Activating screw
19	1	Water rejector
20Δ	1	O-ring
21	1	Air fitting
22	1	Retaining plate
23	1	Threaded plug
24Δ	1	Guide ring
25	1	Spring

Δ: Service Kit  
(See Spare Parts List)

This page shows an exploded drawing of LKLA/  
LKLA-T, size  $\varnothing 133$  mm.  
NC = Normally closed.  
NO = Normally open.

A/A = Air/Air activated.  
The drawing includes all items of the valve.  
They are identical with the items in the Spare Parts List.

## Exploded drawing

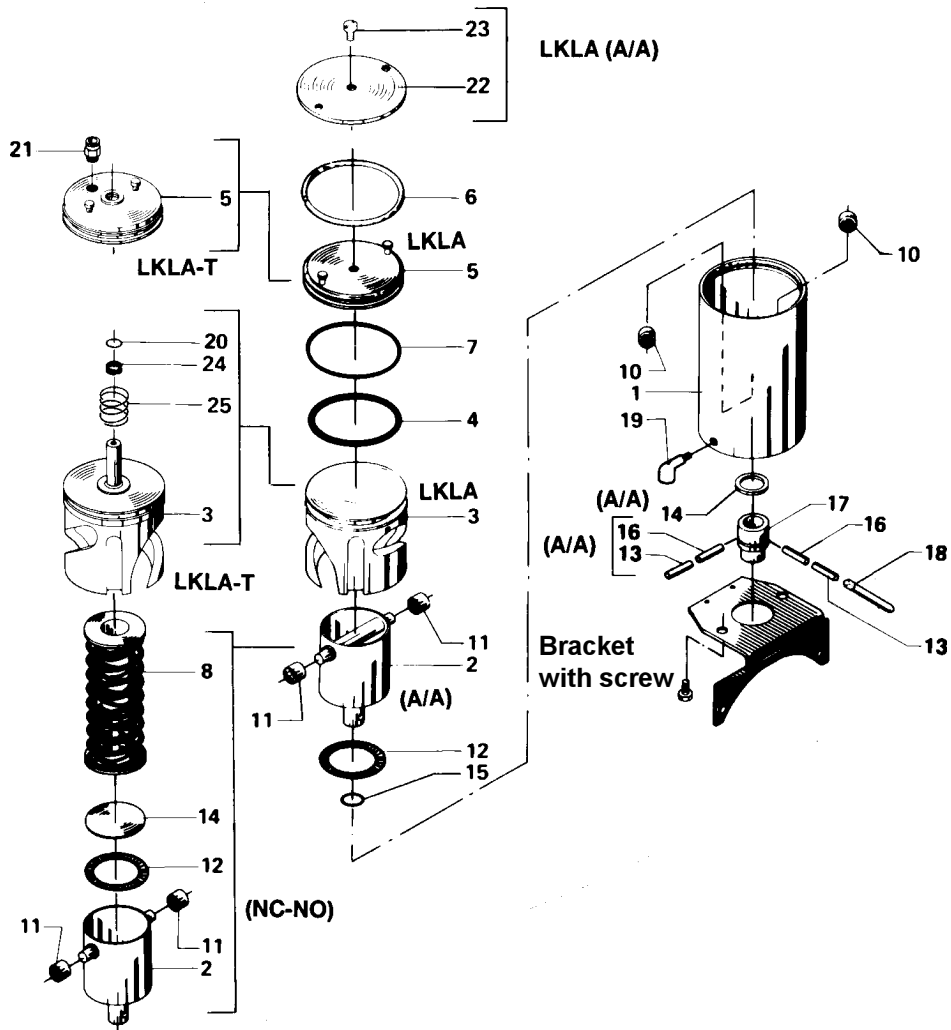

## Drawing/Parts list

The drawings and the parts list include all items.

The items are identical with the items in the Spare Parts list.

When ordering spare parts, please use the Spare Parts List!

### Parts list

#### LKLA/LKLA-T, ø133mm, NC-NO-A/A

36

Item	Qty.	Denomination
1	1	Air cylinder
2	1	Rotating cylinder
3	1	Piston
4Δ	1	O-ring
5	1	End cap
6	1	Retaining ring
7Δ	1	O-ring
8	1	Spring assembly
10Δ	2	Needle bearing
11Δ	2	Needle bearing
12Δ	1	Thrust bearing (A/A)
	2	Thrust bearing (NC/NO)
13	1	Connex pin (NC-NO)
	2	Connex pin (A/A)
14	1	Thrust plate
15Δ	1	O-ring
16	1	Connex pin (NC-NO)
	2	Connex pin (A/A)
17	1	Coupling
18	1	Activating screw
19	1	Water rejector
20Δ	1	O-ring
21	1	Air fitting
22	1	Retaining plate
23	1	Threaded plug
24Δ	1	Guide ring
25	1	Spring

Δ: Service Kit  
(See Spare Parts List)

The drawings below show LKLA/LKLA-T,  $\varnothing 133$  mm,  
NC-NO-A/A.

NC = Normally closed.

NO = Normally open.

A/A = Air/Air activated.

The items refer to the parts list on the opposite part  
of the page.

## Drawings

**LKLA-T (NC-NO)**

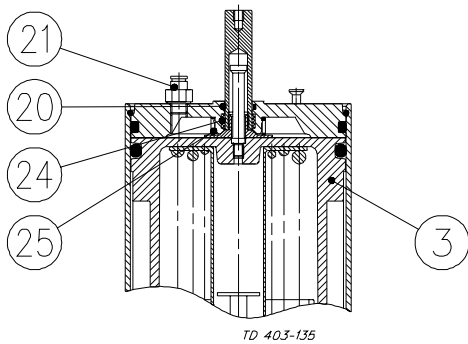

**LKLA-T (A/A)**

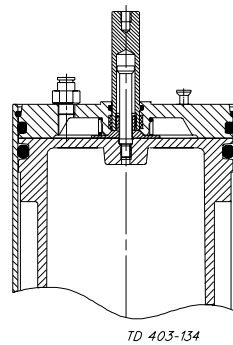

**LKLA (NC-NO)**

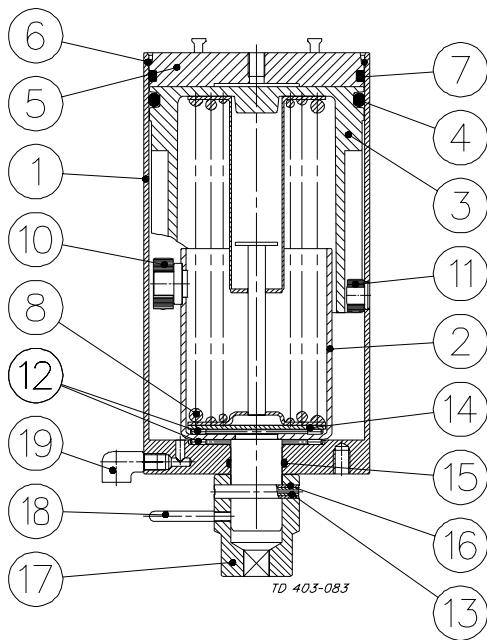

**LKLA (A/A)**

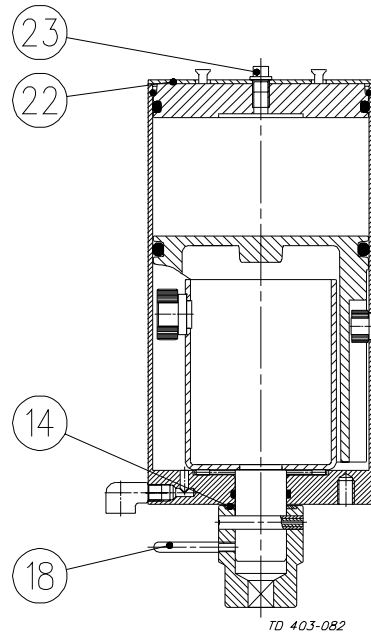

**How to contact Alfa Laval**

Contact details for all countries are continually updated on our website. Please visit [www.alfalaval.com](http://www.alfalaval.com) to access the information direct.